

How to Become a Practicing Astrologer Part I

BY SRI GOSWAMI KRIYANANDA

Copyright © 1994 Goswami Kriyananda

No part of this book may be reproduced in any manner whatsoever
without written permission of the publisher.

Published by The Temple of Kriya Yoga
2414 N. Kedzie, Chicago, Il 60647
(773) 342-4600

Printed in the United States of America

For Your Notes

This is a blank page.

For Your Notes

How to Become a Practicing Astrologer

PART I

TABLE OF CONTENTS

1. Introduction to Astrology (Recording 1)	3
2. The Basic Areas of Astrology (Recording 2).....	11
3. An Introduction to the Planets (Recordings 3 and 4).....	17
4. The Planets: The Cosmic Urges in Detail (Recordings 3 and 4).....	23
5. The Signs of the Zodiac (Recordings 5 and 6).....	53
6. Putting the Planets and the Signs Together (Recordings 5 and 6).....	61
7. The Elements and Qualities (Recordings 5 and 6).....	67
8. The Zodiacal Signs in Detail (Recordings 5 and 6).....	83
9. The Houses of the Horoscope (Recordings 7 and 8).....	105
10. The Aspects in the Horoscope (Recording 9).....	139
11. Delineation of the Planetary Aspects (Recordings 29 and 30).....	203
12. Delineation of Planetary Strengths (Recording 31).....	225
13. A Blending of P.S.H.A. (Recording 32).....	231
14. Constructing the Wheel (Recordings 40 and 41).....	279
15. Placing the Planets in the Chart (Recordings 40 and 41).....	289
Glossary of Basis Astrological Terms.....	301
Answers to Test Questions	347

For Your Notes

Test

1. The Planets' Symbols.....	21
2. Key Words for the Planets	49
3. Key Positive and Negative Words for Each Planet.....	51
4. The Symbols of the Zodiacal Signs	59
5. The Meaning of the Signs of the Zodiac.....	101
6. The Meaning of the Houses	137
7. The Symbols of the Aspects	159
8. The Meaning of the Aspects	161
9. General Information Test, Part 1	177
10. General Information Test, Part 2	199
11. Delineation Test, Part 1	261
12. Delineation Test, Part 2.....	267



1. Introduction to Astrology

RECORDING 1

The first thing I wish to say to you is: do not worry about trying so hard to learn this data. Just listen to the recordings and lightly read over these notes... making notes to yourself, or underlining facts that are important to you. The data will be repeated a number of times to make the learning easy. When it is necessary to memorize something, it will be indicated in the lesson. The self-help tests also indicate what needs to be learned. With this thought in mind, let us begin:

Astrology is the ancient art and science of certain symbolic relationships between the celestial bodies and terrestrial life. Modern science has lately shown what the astrological community has known for millenniums: the universe around us does affect us. It affects our minds, our bodies, our emotions, and our feelings.

There are many branches of astrological study. However, two are basic: natal astrology, and the astrology of the progressed chart. Natal astrology is the interpretation of subtle symbols found in the birth chart or horoscope created for the *time* and *place* of a person's birth. These subtle symbols and their positions reveal personality traits and thus life-patterns. A natal chart can be constructed for the birth of a thing:

For Your Notes

such as a toy, a house, a city, or a nation, etc. Natal astrology is the interpretation of the positions of the planets and other subtler symbols in the chart showing certain proclivities in the life of that person or thing. Natal astrology deals with innate personality traits and subconscious impulses, whatever their cause. This allows you to obtain insight into the hidden forces within you. Natal astrology opposes the general attitude that only conscious forces exist or count. This book focuses on the basic understanding of natal astrology.

Progressed astrology is the interpretation of the movement of the symbols after your birth, in relation to your natal horoscope. These progressed movements of the planets trigger the natal proclivities and cause events and situations to occur. Progressed astrology tells you *when* the subconscious forces, indicated in the natal horoscope, will be activated.

However, astrology is not fatalistic, although many astrologers are. Astrology is an attempt to explain cosmic laws and psychological laws not yet totally understood in the scientific community. Understanding these laws assists in adapting your life to a better, fuller and more meaningful life.

Just as not all medical theories are correct, and some physicians are charlatans, so likewise not all astrological theory is correct, and some

For Your Notes

astrologers are charlatans. Just as knowledge of medicine is far from complete, the knowledge of astrology is also far from complete.

Astrology does not need involvement in any form of psychicism, for astrology is founded upon purely mathematical patterns from astronomical data, from the concepts found in the physics of sound (music), and the discriminating understanding of these symbols.

Astrology is both a science and an art. It is scientific in its mathematical calculations, in its consistency of interpretation, and in its direct correlation with the heavenly bodies. It is an art, like medicine, in that each soul brings their innate skills to that science. Most astrologers refer to astrology in terms of influences of the planets. But, it's not necessary to believe in direct stellar causation. Dr. Carl Jung pointed out that synchronicity, or correlated relationships, could be used to predict personality traits. The mystics declare that personality is destiny.

It is important that you and every student of astrology understand from the very beginning, that the stars incline, they do not compel. Allow me to repeat:

The planets incline, they do not compel!

For Your Notes

Of all sciences, astrology is surely the most spiritual for it insists that *you* can know the meaning of life: terrestrial and celestial.

In the study of astrology you rapidly come to realize that there are no evil forces in nature, only harmonious and inharmonious relationships. The purpose of astrology is to cause you to realize that heaven lies within, and that there need be no conflict between the external and the internal, nor between the terrestrial and the celestial.

Astrology is a spiritual art couched in finite symbols, which are flawless mirrors, revealing to each seeker the glory that is Life. The astrological maxim that the stars only incline, helps us to realize immediately that mankind does have free will, and life is what each of us choose to make it.

The understanding of astrology is the gaining of wisdom, for astrology reveals the patterns-of-destiny. Mankind, since the beginning of time, has tried to see and understand the meaning of those patterns-of-destiny in natural law. It is only when mankind comes to understand that natural law is a mirrored reflection of celestial law, that we truly begin to know The Law which will set each of us free forever. There is a moment of maturity in each soul's life, in which he transcends the bondage of affliction and fear, and seeks to find Truth. This is that moment for you!

For Your Notes

Properly utilized and applied, astrology is the searchlight that allows you to see and recognize that Law. It was Dante who said it best: 'Follow but thy star. Thou canst not miss at last a glorious haven.'



For Your Notes

Study Guide

DATA TO BE MEMORIZED FOR INTRODUCTION TO ASTROLOGY

RECORDING 1

- 1) Astrology is the ancient art and science of certain symbolic relationships between the celestial bodies and terrestrial life.
- 2) There are two key branches of astrological study: natal astrology, and the astrology of the progressed chart.
- 3) Natal astrology is the interpretation of the subtle symbols found in the *birth* chart.
- 4) The progressed chart is the interpretation of the movements of these subtle symbols after birth, in relation to the natal chart. The progressed chart tells you *when* the patterns of the natal chart will manifest.
- 5) A birth chart can be erected for a human being, an animal or an object.
- 6) There are no evil forces, only harmonious and inharmonious relationships.

For Your Notes

- 7) Astrology properly understood reveals the natural order of this life as well as revealing the natural law of the higher realms. Therefore, astrology properly utilized improves the earth life, as well as the spiritual life.

- 8) *The planets incline, they do not compel!*



For Your Notes

This is a blank page.

For Your Notes

2. *The Basic Areas of Astrology*

RECORDING 2

It is extremely easy to learn astrology. It is simple because there are only four basic divisions to understand. The insights gained from astrology are infinite, yet, it can be grasped rapidly. These four basic divisions are:

Planets	(P)
Signs	(S)
Houses	(H)
Aspects	(A)

Mnemonic rule: These four terms can rapidly be memorized by learning the word: PSHA.

PSHA is from an ancient sub-dialect of Persian. It means master. Remember PSHA, and MASTER astrology. Here is the basic explanation of these four terms:

The planets are psychological *urges*.

The signs are *modifiers* of these psychological urges.

The houses tell *where* the modified urges will *manifest*.

For Your Notes

The aspect tells the *strength* and *character* of planets.

The planets are psychological urges. There are two luminaries (the Sun and the Moon), and eight other planets. The Sun and Moon are often referred to as planets for ease of terminology. Thus, we say there are ten planets. The planets rotate counterclockwise.

The signs are modifiers of these psychological urges. There are 12 signs. These signs are also referred to as the signs of the zodiac. They rotate clockwise. A chart, or horoscope, or wheel is a circle. Every circle (no matter what its size) has 360 degrees in it. Because there are 12 signs, each sign is 30 degrees (360 divided by 12 = 30).

The houses tell *where* the modified urge will *manifest*. The 12 houses are like 12 pieces of pie that make up a circle called a chart, or horoscope. The houses never move.

An aspect tells about the *strength* and *character* of the planets involved. An aspect is a specific distance between planets. Aspects show how strong or weak the energy is between two or more planets. Aspects, also, show whether the energy is harmonious or inharmonious. There are only five major aspects.

For Your Notes

Just as distance between buildings is measured in feet, and distance between cities is measured in miles, so likewise, the distance between planets is measured in ‘degrees.’

The Planets, Signs, Houses and Aspects all function together, revealing the person’s personality and life patterns.

When the zodiacal signs and planets are calculated for the person’s birth time, and placed into a wheel of 12 houses (sections of pie), it is called a birth chart, or a natal horoscope.

Now, whenever most people start to learn something new, they seem to be swamped with many terms and concepts that make them doubtful whether they can really learn the new subject. I assure you that you can learn astrology, and with relative ease. This program is divided into simple, logical steps so that you will not feel overwhelmed.

Learning astrology is like learning a foreign language. Indeed, astrology is the language of the soul. However, the language of astrology has only 40 terms and 28 symbols in its basic vocabulary: If you learn one term or symbol a day, it will take you about two months to learn astrology. If you memorize three terms or symbols a day, it will take you only three weeks to learn astrology. However, it takes a little longer to master the

For Your Notes

subject. Nonetheless, the joy of learning and of seeing into the true nature of things makes the journey a delight; makes learning easy.

Study each section of this program fully. Set aside a specific amount of time each day to study. If possible set aside a specific place to learn. Set a specific goal regarding data to be memorized each day. Review your data often.



For Your Notes

Study Guide

DATA TO BE MEMORIZED FOR THE BASIC AREAS OF ASTROLOGY

RECORDING 2

1. The four basic areas of astrology are symbolized by the word: **PSHA**.
2. **PSHA** stands for:

PLANETS

SIGNS

HOUSES

ASPECTS
3. The 10 *planets* move, and are psychological *urges*.
4. The 12 *signs* move, and *modify* these planetary urges.
5. The 12 *houses* do not move, and they indicate *where* these modified urges will *manifest*.

For Your Notes

6. The five major *aspects* show the *strength* and *character* of the planetary energy. Aspects are a distance from one planet to another. This distance is measured in 'degrees.' Some aspects produce harmonious attitudes or events in your life, other aspects produce inharmonious attitudes or events.



For Your Notes

3. An Introduction to the Planets

RECORDINGS 3 AND 4

The first thing to be done in learning astrology is to memorize each planet's name, its symbol and the key words expressing its urges.

Here are their names, and the order in which the planets are to be memorized. The order is from the fastest moving planet, to the slowest moving planet:

Moon, Mercury, Venus, Sun, Mars, Jupiter, Saturn, Uranus, Neptune, Pluto.

Mnemonic rule: the first letter of the first five planets is: MMVSM. Write it this way: 2M VS M. You now have the order of the first five planets.

2M = Moon and Mercury

VS = Venus and Sun

M = Mars

Mnemonic rule: the first letter of the second five planets is: J SUN P. Write it this way: J-SUN-P. Thus you have the order of the last five planets.

For Your Notes

J = Jupiter

SUN = Saturn, Uranus, Neptune

P = Pluto

Now that you are introduced to the names of the 10 planets, you need to relate each planet to its symbol. The planetary symbols are formed from three basic symbols: the Circle, the Crescent, and/or the Cross.

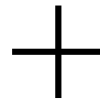
The *circle* symbolizes Consciousness or Eternality.The *crescent* symbolizes the mind.The *cross* symbolizes matter.

For Your Notes

Study Guide

DATA TO BE MEMORIZED FOR AN INTRODUCTION TO THE PLANETS

RECORDINGS 3 AND 4

A) The names and the symbols of the planets are:

	NAME	SYMBOL
1.	The Moon	☾
2.	Mercury	☿
3.	Venus	♀
4.	The Sun	☉
5.	Mars	♂
6.	Jupiter	♃
7.	Saturn	♄
8.	Uranus	♅
9.	Neptune	♆
10.	Pluto	♇ or ♇

Remember to memorize the 10 planets in the above order.

For Your Notes

- B) Take your first set of planetary flash cards and cut them out. Placing the names of the planet toward you, memorize the planet's symbol. Shuffle the cards often, and study them. Study them from both sides: planets to symbols, and symbols to planets. Memorize them and find joy in studying and mastering these names and symbols.



For Your Notes

How to Become a Practicing Astrologer
Self-evaluation Test #1

Please draw in the correct symbol for each planet below:

1. _____ is the symbol for Venus.

2. _____ is the symbol for Pluto in America.

3. _____ is the symbol for Mars.

4. _____ is the symbol for Mercury.

5. _____ is the symbol for the Moon.

6. _____ is the symbol for Uranus.

For Your Notes

7. _____ is the symbol for Jupiter.

8. _____ is the symbol for Neptune.

9. _____ is the symbol for Saturn.

10. _____ is the symbol for the Sun.

11. _____ is the symbol that the Europeans use for Pluto.



For Your Notes

4. Planets: The Cosmic Urges in Detail

RECORDINGS 3 AND 4

Thus far we have talked about the names and symbols of the planets and their order from the fastest moving to the slowest moving.

Now we will concentrate on the meaning of the basic *planetary urges*. These basic meanings will help you keep in mind the urges of each planet. All other words only extend your understanding of those basic urges. Gradually, your vocabulary for each of the planets will increase and you will be able to understand them in greater depth. We'll begin with the Moon, the fastest moving planet, and proceed to Pluto, the slowest moving planet.



THE MOON: The crescent or half circle symbolizes man's mind, and the key words denoting the urges of the Moon are:

Emotionality Response Fluctuation

It is the Moon that determines a person's mannerisms and his observable behavior. Thus, the Moon is the indicator of one's

For Your Notes

personality. The Moon relates to infancy and/or babies. The Moon waxes (grows bigger) and wanes (grows smaller), and therefore relates to being changeable, revealing the fanciful side of a person's nature.

When a planet is well aspected it manifests positive urges. When a planet is poorly aspected, it manifests negative urges.

The symbolic psychological meaning of the Moon in its *positive component* is changeability, receptivity, mobility, domesticity, motherliness (in the sense of caring for others), memory (in the sense of form). These qualities of the Moon produce carefulness, prudence, practicality, sympathy, and an affectionate nature.

The symbolic psychological meaning of the Moon in its *negative factor* is a non-caring for others, lacking any concern for others, moodiness, love of comfort, and the capacity to be easily influenced. These qualities of the Moon produce a negative sensitivity, impressionability, shrewdness, clannishness, prejudicial attitudes, narrow-mindedness, and excessive self-concern, as well as a tendency to dwell in and with the past. The Moon, also, tends toward shyness, timidity, yet manifesting a dominant, tenacious personality. The Moon relates to one's imagination.

For Your Notes



MERCURY: The symbol of communications. The mind (the crescent) sits above the circle of Spirit, and both are above the material cross.

It is Mercury which governs the urge to communicate. It shows one's mentality and the type of nervous reactions he will have. Mercury relates to early childhood and has to do with communication and transportation. In mythology, the messenger of the gods was the winged Mercury. Mercury encompasses logic, duality, youthfulness, and speed. The key words denoting the urges of Mercury are:

Communication Mentality Transportation

The principle of Mercury is the principle of the intellect and communications. The symbolic psychological meaning of Mercury when *positive* is sound judgment, diplomacy, dexterity, keen observation, lucidity, and perceptiveness. It also relates to one's being skillful, brilliant, articulate, and resourceful.

The symbolic psychological meaning of Mercury when *negative* is shrewd, forgetful, indecisive, careless, nervous, diffusive, imitative,

For Your Notes

shiftless, skeptical, verbose, unstable, restless. It can also bring a lack of understanding as well as a failure to have objectivity.

Just as the Moon showed us about change and reactivity to change, the planet Mercury has a great deal to do with one's ability to adapt.



VENUS: Venus is symbolized with the circle of Spirit over and thus controlling the material cross (the things of this world).

The key words denoting the urges of Venus are:

Love Harmony Unison

It is Venus that determines the way a person romantically relates to others, as well as the ability to attract others. It gives a refined and gentle character, making one agreeable. Venus rules the sense of touch and also, to a very great degree, the disposition. Consequently, Venus' influence brings a kind, loving, and generous personality with good humor. Venus, also, symbolizes the state of adolescence.

In medicine, its symbol is the female. In mythology, Venus was the goddess of love. Venus is considered the planet of adaptation which therefore produces harmony. Venus is called the lesser benefic and

For Your Notes

produces tenderness and love. It is the brightest of the planets in the solar system. At night only the Moon is brighter. Venusian forces can promote a refinement of the mind in poetry, art, music, drama, painting, and singing.

The symbolic psychological meaning of Venus when it is *positive* is a positive attitude toward life, a sense of harmony, and a sense of beauty, producing psychological urges that are affectionate, chaste, sympathetic, contented, graceful, and humane. It gives a placid, impartial, fair disposition, refined and fond of social pleasures. Venus, in and of itself, is not suited for disagreeable nor arduous work.

The symbolic psychological meaning of Venus when it is *negative* is sentimentality, heedlessness, bad taste, sensual aberration; immodest, lewd, emotional, indolent, loud, untidy, gaudy, and excessive, careless, a lack of enterprise, laziness, a lack of confidence, an attitude of daydreaming, impracticality, and often a parasitic attitude.

For Your Notes



THE SUN: The full circle is the symbol of Spirit, or of eternity. The dot in the center of that circle symbolizes the self conscious awareness we have of that eternity. The Sun symbolizes the urges of:

Power Vitality Self-Expression

From the Sun comes the life-giving warmth and power which allows the earth to blossom and live. The Sun in a chart represents the person, his character, and his individuality. It shows that which sets him apart from others and makes him what he is. The Sun's action is vitalizing and fortifying to whatever planet(s) it is aspected.

The symbolic psychological meaning of the Sun when it is *positive* is honorable, lofty, faithful, friendly, dignified, distinguished, loyal, generous, grateful. It also represents authority, leadership, the ability to make decisions, and an organizational capacity. The Sun also symbolizes general prosperity, rank, and title.

The symbolic psychological meaning of the Sun when it is *negative* is lack of vitality, vacillation, arrogance, indolence, ego, vanity, despotism, dictatorship, jealousy, pride, haughtiness, and authoritativeness.

For Your Notes

When a person begins to learn about astrology he usually wants to know what Sun-sign he is. This refers to the sign that the Sun occupies in his natal horoscope.



MARS: The cross of materiality sits above the symbol of Spirit.

Consequently, the things of this world, rather than those of the Spirit, rule. The key words denoting the urges of Mars are:

Energy Heat Activation

Mars decides what kind of pioneering action the person will have, his energy level; whether or not he can become heated in thought, and emotion; or feverish with physical illness. It is the red planet and symbolizes force, courage, strength, aggression, power, animal strength, ambition, and desire. Those ruled by Mars are bold, enterprising, and have a positive love of leadership. Their ruler, the god of war, usually imbues them with highly inventive natures. They dislike being told what to do, however, they love to tell people what to do, and also how to do it. Mars' action is assertive, sudden, and sometimes disruptive.

The symbolic psychological meaning of Mars when it is *positive* is energetic, impulsive, assertive, expressive, possessive, enthusiastic,

For Your Notes

frank, bold, fearless, determined, venturesome, strong, active, constructive, and passionate. Mars gives physical activity, endurance, push, courage, enterprise.

The symbolic psychological meaning of Mars when it is *negative* is defiant, violent, jealous, harsh, hateful, sarcastic, quarrelsome, vulgar, reckless, brutal, cruel, contemptuous, irritable, impatient, combative, sensual, destructive, and audacious. These individuals are quarrelsome, self-opinionated, and excessive in words and actions. They are restless, indecisive, and are more apt to do things by and for themselves. They give an innate feeling that no one else can do it quite as well as they can. There will be a love of personal freedom and dislike for any form of interference in their life, yet a strong Mars will cause them to try to interfere in others' lives.

For Your Notes

2 | JUPITER: The mind (the crescent) is to the side and slightly above the materialistic cross, thus the mind rules. The key words denoting the urges of Jupiter are:

Expansion Preservation Optimism

Jupiter decides a person's tendency toward cheerfulness, joviality, and expansive ways. Whatever Jupiter is linked to in the horoscope, that thing or event expands. Jupiter is the largest of all the planets in our solar system, after the Sun. Wherever Jupiter is found in the chart, it is in that area of one's life that there will be a tendency to do things on a large scale, in an expansive manner, and with optimism. It governs the urge for knowledge and wisdom, compassion and sociability.

The symbolic psychological meaning of Jupiter when it is *positive* is expansion, enlargement, justice, generosity, charitability, compassion, philanthropy, and benevolence. Jupiter also rules over sports including hunting and athletics. It rules the love of animals, religion, law, and philosophy.

The symbolic psychological meaning of Jupiter when it is *negative* is extravagance, shiftlessness, dissipation, pretentiousness, indulgence, excessiveness, over-confidence, gullibility, and pomposity.

For Your Notes



SATURN: Saturn is the opposite of Jupiter. The cross of matter sits over the crescent, and the key words denoting the urges of Saturn are:

Limitation Cold Constriction

Saturn decides a person's ability to control and achieve security. Because of its limitation, it is known as the greater malefic. Saturn has to do with seriousness and depression. Saturn's action is slow but thorough, and inevitable. It relates to that which is most concrete and most practical. The principle of Saturn is inhibition, limitation, and contraction.

The symbolic psychological meaning of Saturn when it is *positive* is concentrated, practical, strict, thrifty, hard-working, patient, self-disciplined, responsible, dutiful, diplomatic, cautious, precise, reserved, mathematical, serious, persevering, and profundity of executive abilities.

The symbolic psychological meaning of Saturn when it is *negative* is skeptical, melancholic, pessimistic, slow, suspicious, exacting, selfish, severe, sad, suppressed, rigid, miserly, narrow-minded, vengeful, inhibited, seclusive, and acquisitiveness.

For Your Notes

Saturn is the symbol of Karma, and thus is one key indicator of the tests that will come into one's life. However, through its tests, delays, and disappointments, mankind learns to be patient and wise.

Saturn is the greater malefic and is truly our taskmaster, yet, he is the greatest friend a person can have, for Saturn teaches; we learn from him and thus improve our life. Gains through Saturn are great and permanent; losses are also permanent.



URANUS: Here the symbol of the mind is on both sides and above the cross of material things; these stand above the circle of Spirit. The key words denoting the urges of Uranus are:

Unexpected Reactionary Extreme Change

Uranus is known as a malefic and often thought of as a higher octave of Saturn. It is thought to be connected with sudden pain, and governs the urge toward rebellious freedom and unconventionality; it also relates to genius. Uranus correlates with astrology. Uranus' action is unexpected, sudden, and usually drastic. The principle of Uranus is suddenness, unexpectedness, and revolution.

For Your Notes

The symbolic psychological meaning of Uranus when it is *positive* is progressive, intuitive, magnetic, impersonal, liberty-loving, scientific, ingenious, independent, non-conforming, inventive, reforming, restless, impulsive, altruistic, peculiar, freedom loving, excitable, irritable, enthusiastic for the new, original, talented, metaphysical, and clairvoyant. Some of the basic qualities of Uranus are versatility and originality. It has to do with awakening and is referred to as the planet of genius and illumination. Uranus rules modern art or anything associated with the unusual.

The symbolic psychological meaning of Uranus when it is *negative* is obstinate, rebellious, revolutionary, impulsive, changeable, radical, impractical, eccentric, disruptive, fanatical, dictatorial, perverse, irresponsible, outspoken, explosive, resentful, fantastic, abnormal, extreme, erratic, and premature. It rules electricity, and things which run on electricity, this includes telephones, telegraphs, radios, TV and all electronic devices, as well as airplanes.

Uranus often reacts much like the Sun, tending to seek out conditions of power and responsibility. This shows itself very strongly in United States' presidents with a strong Uranus in their natal charts.

For Your Notes

Uranus is the planet of unpredictability for it always brings things to pass suddenly, unexpectedly, and in ways undreamt. Uranus always brings things to pass with some extraordinary departure from the norm.



NEPTUNE: The mind is uppermost, because it is above the cross of materiality. The key words denoting Neptune's urges are:

Nebulousness Impressionability Inspiration

Neptune shows the urge toward the non-material, the unconfined, the mystical, and the spiritual. Being a higher octave of Jupiter, Neptune has to do with ephemeral and nebulous things which are hidden from view. The Greek name for Neptune was 'Poseidon,' which means 'ruler of the waters.' Its symbol resembles the trident carried by the god Neptune, king of the oceans. As such, it is related to liquids, intoxicating liquors, alcohol, drugs, anesthetics, and gases. Neptune has a great deal to do with any mysterious conditions, hidden natures, secret affairs, detective work, investigative work, or anything dealing with spiritualism.

Neptune's action is gradual and subtle, sometimes insidious. The principle of Neptune is susceptibility and sympathetic understanding.

For Your Notes

Neptune is one of the more recently discovered planets and many astrologers see in this planet a delicate nature, producing a sense of idealism, spirituality, with artistic and musical talent that is similar to the planet Venus.

The symbolic psychological meaning of Neptune when it is *positive* is inspirational, sympathetic, compassionate, mystical, psychical, clairvoyant, poetic, reverent, imaginative, idealistic, musical, intuitional.

The symbolic psychological meaning of Neptune when it is *negative* is indulgent, deceptive, vague, dreamy, confused, fearful, deluded, susceptible, self-deceptive, super-sensitive, misunderstood, obsessed, and negative. Neptune often causes a person to worry a great deal.

Neptune tends to produce bodily and/or mental conditions that are subtle and therefore extremely difficult to diagnose. Many astrologers feel that the force of Neptune is more psychic and mental rather than physical. However, this is not always true, particularly in the case of health conditions. Neptune rules the nerves.

For Your Notes



PLUTO: The circle of Spirit is encased in the mind, and both are above the material cross. The key words denoting the urges of Pluto are:

Transformation Regeneration Subconsciousness

Pluto is the newest of the discovered planets, discovered in 1930. Pluto is considered the higher octave of Mars. Its urge is to produce quick elimination, the ability to get rid of the unnecessary, and begin again.

The principle of Pluto is transforming, coercing, having invisible forces and providence as well. The action of Pluto seems to indicate the beginning of things as well as the ending of things; the beginning and ending of chapters in one's life; the beginning and ending of life itself.

The symbolic psychological meaning of Pluto when it is *positive* is transformation, transmutation, rejuvenation, revitalization, regeneration, exaltation, and transition. Many astrologers maintain that Pluto is the planet of interstellar travel, spaceships, flying saucers, etc.

The symbolic psychological meaning of Pluto when it is *negative* is death, decomposition, destruction, recklessness, struggle, fanaticism,

For Your Notes

sensuality, adventurousness. Persons with a strong Pluto in their chart can tend to be dictatorial.

A strong Pluto symbolizes persons who exert a charisma over masses of people such as actors, politicians, public speakers, propagandists, and religionists, etc.

The action and urges of Pluto are like that of Mars with three exceptions. The first is that Pluto causes a duplication or a repetition of conditions. Secondly, Pluto relates to the masses. Thirdly, Pluto's coercive force exists more within the unconscious mind. Pluto has a transforming force, and is consequently often referred to as the phoenix symbol. (Mars' forces are more conscious, generally deal with one on one, and as a rule, cause an event to happen only once).

In mythology, Pluto is the king of the underworld and, as you may know, the first kidnapper. With this in mind, it is interesting to note that Pluto was discovered in March of 1930 at which time the United States experienced waves of kidnapping. It was a time of great emergence of gangsters and underworld activities. Also, it was during this time that huge, massive activities evolved, such as labor strikes and mass emigration to many parts of the world. This is an indicator that Pluto deals with the masses and, also, the underworld.

For Your Notes

The Planets

RECORDINGS 3 AND 4

Additional Key Words for the Planets

HARMONIOUS

INHARMONIOUS

MOON:	Receptive	Shy
	Sympathetic	Non-caring
	Adaptable	Moody
	Motherly	
MERCURY:	Good judgment	Indecisive
	Diplomacy	Careless
	Articulate	Nervous
VENUS:	Affectionate	Untidy
	Graceful	Gaudy
	Refined	Excessive
SUN:	Loyal	Arrogant
	Dignified	Dictatorial
	Generous	Lack of vitality

For Your Notes

MARS:	Energetic	Harsh
	Expressive	Reckless
	Determined	Destructive
JUPITER:	Justice-seeking	Extravagant
	Generous	Indulgent
	Compassionate	Yearning for pleasure
SATURN:	Responsible	Melancholic
	Hard-working	Pessimistic
	Self-disciplined	Narrow-minded
URANUS:	Magnetic	Rebellious
	Ingenious	Fanatical
	Inventive	Erratic
NEPTUNE:	Sympathetic	Deceptive
	Poetic	Vague
	Intuitional	Obsessed
PLUTO:	Rejuvenating	Fanatical
	Transforming	Reckless
	Repetitive	Notoriety

For Your Notes

Retrograde Planets

RECORDINGS 3 AND 4

1. The Sun and the Moon never go retrograde.
2. When Mercury is retrograde it indicates that the thinking processes are more subconscious than conscious.
3. When Venus is retrograde it indicates an obstruction or complication in one's love life and/or in one's social relationships.
4. Mars retrograde indicates that the energies are more of an obstructive, fighting nature, and tends to bring about more gruff or rough personality traits.
5. Jupiter retrograde indicates a personality that does not follow the standard route towards wealth, psychological or spiritual abundance. A retrograde Jupiter indicates a person who tends to take more chances in life.

For Your Notes

6. Saturn retrograde indicates a person who tends to be more fatalistic in life, and it oftentimes indicates problems with bad timing.
7. Uranus retrograde tends to indicate a person who is more rebellious and oftentimes seeks freedom at any price.
8. Neptune retrograde tends to indicate a person who feels it necessary to make other people aware of their self-aggrandizement.
9. Pluto retrograde tends to produce a greater degree of subconscious frustration.



For Your Notes

The North and South Nodes

THE NORTH NODE:  THE SOUTH NODE: 

The North and South Nodes of the Moon are not planets, they are points on the ecliptic that are used to indicate or show when eclipses will manifest. The Moon's nodes are not discussed in Part 1 of the course but will be discussed at a later time.

The Part of Fortune

THE PART OF FORTUNE: 

We also have not dealt with the Part of Fortune which is an Arabian Part. It is one of the many mathematically calculated points in the horoscope. The Part of Fortune indicates an important area where wealth or material things will manifest or flow easily into a person's life. The exact time of birth, however, must be known to calculate this or any of the other Arabian Parts. These will be discussed at a later time.



For Your Notes

Study Guide

THE PLANETS

RECORDING 4

Mnemonic Rule for the Planets and Their Order of Memorization

MM VS MJ

SUN P

Moon - Mercury ... Venus - Sun ... Mars - Jupiter

Saturn - Uranus - Neptune ... Pluto



For Your Notes

Study Guide

THE PLANETS

RECORDING 4

Here are some additional keywords for the planets:

The Moon	☾	= the urge for change
Mercury	☿	= the urge to communicate
Venus	♀	= the urge to love; harmony
The Sun	☼	= the urge for power, for life
Mars	♂	= the urge to be aggressive
Jupiter	♃	= the urge for expansion
Saturn	♄	= the urge for confinement
Uranus	♅	= the urge for freedom and sudden, radical change
Neptune	♆	= the urge for inspiration, nebulosity
Pluto	♇	= the urge for renewal, regeneration



For Your Notes

Study Guide

DATE TO BE MEMORIZED
FOR THE COSMIC URGES IN DETAIL

RECORDINGS 3 AND 4

Here are the key words for understanding the *urges* of the planets:

MOON:	Emotionality
MERCURY:	Communication, Transportation, Mentality
VENUS:	Harmony, Unison, Love
SUN:	Vitality, Self-expression, Power
MARS:	Activation, Energy, Heat
JUPITER:	Expansion, Optimism, Preservation
SATURN:	Limitation, Constriction, Cold
URANUS:	Unexpected, Reactionary, Extreme Change
NEPTUNE:	Nebulousness, Impressionability, Inspiration
PLUTO:	Transformation, Regeneration, Subconsciousness

Remember: These words are indications of the planetary urges. There are other words that can be used. You may use your own words if that helps you. However, be sure that your words have the same meaning as the words above.

For Your Notes

Use your second set of planetary flash cards to study the urges or key words. Shuffle them often and study them throughout the day. You will notice that in this set the symbols of the planets are used, instead of the words, to help reinforce your learning.



For Your Notes

This is a blank page.

For Your Notes

How to Become a Practicing Astrologer
Self-evaluation Test #2

In the space provided below, write one to three key words for each planet:

1. A few key words for Mars are

2. A few key words for Neptune are

3. A few key words for Jupiter are

4. A few key words for the Sun are

5. A few key words for Mercury are

6. A few key words for Pluto are

For Your Notes

7. A few key words for the Moon are

8. A few key words for Venus are

9. A few key words for Uranus are

10. A few key words for Saturn are



For Your Notes

How to Become a Practicing Astrologer
Self-evaluation Test #3

Please fill in a single key word symbolizing the positive or negative characteristics attributed to each planet.

1. A key word for Mercury when it is positive: _____

A key word for Mercury when it is negative: _____

2. A key word for Uranus when it is positive: _____

A key word for Uranus when it is negative: _____

3. A key word for the Moon when it is positive: _____

A key word for the Moon when it is negative: _____

4. A key word for Neptune when it is positive: _____

A key word for Neptune when it is negative: _____

For Your Notes

5. A key word for Venus when it is positive: _____

A key word for Venus when it is negative: _____

6. A key word for Mars when it is positive: _____

A key word for Mars when it is negative: _____

7. A key word for Saturn when it is positive: _____

A key word for Saturn when it is negative: _____

8. A key word for Pluto when it is positive: _____

A key word for Pluto when it is negative: _____

9. A key word for Jupiter when it is positive: _____

A key word for Jupiter when it is negative: _____

10. A key word for the Sun when it is positive: _____

A key word for the Sun when it is negative: _____



For Your Notes

5. The Signs of the Zodiac

RECORDINGS 5 AND 6

This section deals with the signs of the zodiac, their symbols and their meanings. The word zodiac is an Arabian term meaning, ‘circle of animals.’ This circle of animals consists of 12 special groups of stars. They are special because they are grouped around the ecliptic—the path of the Sun. There are thousands of star-groups called constellations. But only those constellations that are on either side of that ecliptic by approximately 24 degrees are known as Constellations of the Zodiac.

Earlier we talked about the 10 planets that exist in our solar system. We are now talking about constellations of stars that exist far, far beyond our solar system.

The zodiac, being a circle, measures 360 degrees. If we divide the 12 signs of the zodiac into the 360 degrees, we find that each sign measures exactly 30 degrees.

For Your Notes

At this time it is necessary to know:

- a) the names of these signs
- b) their symbols
- c) their order
- d) their meaning

- 1) The first six signs are to be memorized in this order:

Aries, Taurus, Gemini, Cancer, Leo, and Virgo.

Mnemonic rule. A.T.G.C.L.V = AT Georgia, Carol Loved Victor.

The last six signs are to be memorized in this order:

Libra, Scorpio, Sagittarius, Capricorn, Aquarius, Pisces.

Mnemonic rule: L.S.S. C.A.P. = LoSS-CAP.

- 2) That is the order of the 12 signs. Now, you will note that the 12 signs not only have an exact order, but that certain signs are *always* opposite certain other signs. This order never changes even though the signs rotate around the chart in clockwise motion. This opposition order is as follows:

For Your Notes

- | | |
|-----------|----------------|
| 1. Aries | 7. Libra |
| 2. Taurus | 8. Scorpio |
| 3. Gemini | 9. Sagittarius |
| 4. Cancer | 10. Capricorn |
| 5. Leo | 11. Aquarius |
| 6. Virgo | 12. Pisces |

Aries is always opposite Libra.

Taurus is always opposite Scorpio.

Gemini is always opposite Sagittarius.

Cancer is always opposite Capricorn.

Leo is always opposite Aquarius.

Virgo is always opposite Pisces.

Symbols of the Zodiac

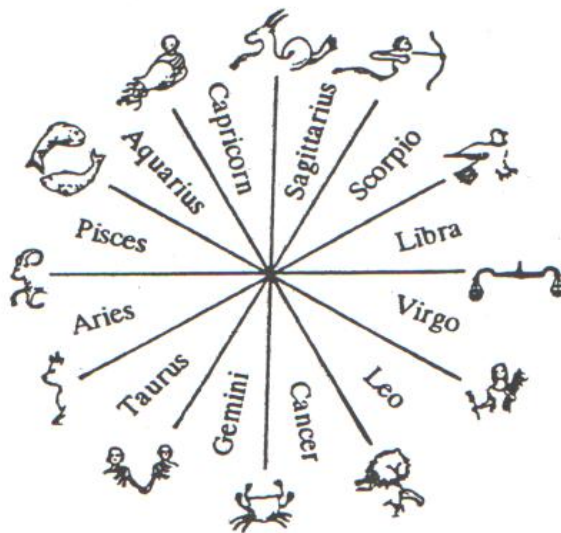

For Your Notes

- 3) The next step is to learn the symbol for each sign. It is not necessary to memorize its glyph.

Zodiacal

	Sign	Symbol		Glyph
1.	Aries		horns of a ram	
2.	Taurus		horns of a bull	
3.	Gemini		the twins	
4.	Cancer		claws of a crab	
5.	Leo		tail of a lion	
6.	Virgo		the virgin	
7.	Libra		the scales	
8.	Scorpio		stinger of the scorpion	
9.	Sagittarius		arrow of the archer's bow	
10.	Capricorn		the sea goat	
11.	Aquarius		the astral water carrier	
12.	Pisces		the fish	

For Your Notes

- 4) The next step is to understand that the signs *modify* the planetary *urges*. Here are the key modifying words for the signs:

Aries:	assertively, aggressively
Taurus:	possessively, enduringly
Gemini:	communicatively, mentally
Cancer:	protectively, emotionally
Leo:	joyfully, creatively
Virgo:	critically, analytically
Libra:	harmoniously, graciously
Scorpio:	passionately, penetratingly
Sagittarius:	expandingly, philosophically
Capricorn:	coolly, aspiringly
Aquarius:	detachedly, persistently
Pisces:	confusedly, nebulously

There are other positive and negative terms that will be added to this list later on.



For Your Notes

Study Guide

DATA TO BE MEMORIZED
FOR THE SIGNS OF THE ZODIAC

RECORDINGS 5 AND 6

- A) Study your three sets of zodiacal sign flash cards: first the symbols, and then the modifying words. Memorize the symbols and their meanings before going on to the next section.

- B) It might help to relisten to the learning recording on the signs, and to reread this whole section.



For Your Notes

How to Become a Practicing Astrologer
Self-evaluation Test #4

Please draw in the correct symbol for each zodiacal sign below:

1. _____ is the symbol for the zodiacal sign Libra.
2. _____ is the symbol for Taurus.
3. _____ is the symbol for Leo.
4. _____ is the symbol for Aries.
5. _____ is the symbol for Virgo.
6. _____ is the symbol for Pisces.
7. _____ is the symbol for Cancer.
8. _____ is the symbol for Aquarius.

For Your Notes

9. _____ is the symbol for Capricorn.

10. _____ is the symbol for Gemini.

11. _____ is the symbol for Scorpio.

12. _____ is the symbol for Sagittarius.



For Your Notes

6. Putting the Planets and Signs Together

RECORDINGS 5 AND 6

This short, but vital section shows you how the planets and the signs of the horoscope go together. To give an idea of how easy and how valuable astrology can be, I will use a few examples.

Remember:

The planets are psychological urges.

The signs are modifiers of those urges.

Thus, if you wanted to know the love nature of four people that you know, you would look at Venus because Venus is the urge to love.

Now, if the first person had Venus in Aries, you would say to yourself, 'Venus in Aries is the urge to love assertively.'

If the second person had Venus in Capricorn, you would think to yourself, 'Venus in Capricorn is the urge to love coolly.'

If the third person had Venus in Scorpio, you would think, 'Venus in Scorpio is the urge to love passionately.'

For Your Notes

If the fourth person has Venus in Gemini, you would know that Venus in Gemini is the urge to love communicatively.

Thus, you can see at a glance, their love nature. Which one would you pick? Now, having seen the love nature of each person you might wish to inquire whether they like to argue or not.

Mars is the urge to fight. So, you check the sign that Mars is in. Let's say:

One person has Mars in Aries.

Another has Mars in Taurus.

Another has Mars in Virgo.

And the last person has Mars in Gemini.

This would tell you that:

The first person has the urge to fight assertively.

The second person has the urge to fight enduringly.

The third person has the urge to fight detailedly.

The fourth person has the urge to fight verbally.

Again, which person would you like to be closer to?

For Your Notes

Another example would be, if you were going to hire a person and you had two choices. Mercury is the planet of communications and also of business. One person had Mercury in Leo. The other person had Mercury in Pisces. Based on the following data, which one would you hire?

Let's see ...

Mercury in Leo is the urge to communicate joyfully.

Mercury in Pisces is the urge to communicate defusedly.

Of course, to get a deeper, fuller insight, more than one planetary factor can be considered. However, many other factors will not neutralize a planet's placement: Mars in Aries... is Mars in Aries.



For Your Notes

Things to Do

- A) Mentally, go through all the planets, and place each planet in each of the signs. Be sure that you use the phrase ‘the urge to...’ for the planet, and the proper modifier for the sign. For example with Jupiter in Aries, say: ‘The urge to expand aggressively.’
- B) Take the flash cards for the planet’s urges, and shuffle them up. Then take the flash cards for the signs with the modifying words and shuffle them up. Place the two piles of cards next to each other, the planetary cards to the left.

If the top card on the planetary pile is Mars, and the top card on the zodiacal sign pile is Cancer, read it thus: the urge to fight cautiously.

Now, turn over the next card on the sign pile. If it is Sagittarius, read it: the urge to fight philosophically.

Now keep turning over the sign cards, until you are all the way through the sign cards. At this point, shuffle the sign cards. Now turn over the Mars card. If the next planetary card is Venus, and the first sign card is Gemini, read it: the urge to love communicatively.

For Your Notes

Now turn over the sign card and read Venus in whatever sign card comes up. When you have finished all the planetary cards, you can reshuffle them and start again.

Do this important exercise until you can effortlessly read any planet in any sign.

Remember to try to use more than one term for each planetary urge. Don't get stuck with using only one term.



For Your Notes

This is a blank page.

For Your Notes

7. The Elements and Qualities

RECORDINGS 5 AND 6

There are four *elements* and three *qualities* that relate to the signs in astrology. Each sign is made up of one element and one quality.

The four elements are:

Fire, Earth, Air and Water

These are not chemical elements, but symbolic states of consciousness. They are metaphysically more basic than the physical elements. Here is a representation of the four elements in astrology:

Fire Any sign which has fire as its element, will give an ardent, keen force, bestowing energy and activity.

Earth The earth element symbolizes the practical, cautious force. It is concerned with the practical everyday affairs.

For Your Notes

Air The air element symbolizes the intellectual, communicative force. It relates to relationships with people.

Water The water element symbolizes the emotional, sensitive force. It relates to the emotional, creative, and psychic nature.

There are three *qualities*. These qualities are represented by the following attributes:

Cardinal signs symbolize push, and activity. Its key force is its outgoingness. Cardinal signs show a free manifestation in the external world. Cardinal signs produce a restlessness. The cardinal sign asks, 'How will this action affect what I want to do?' Cardinal signs are always changing. People with many planets in cardinal signs are people of action, leaders with marked goals.

Fixed signs symbolize feelings, and the pleasure-pain aspect of the world. The fixed quality implies a force resistant to change, therefore, fixed signs are stable and conservative, but with strong likes and dislikes. They seldom change. They ask, 'Is this going to be pleasant or unpleasant?'

For Your Notes

People with many planets in fixed signs are land-owner types of personalities.

Mutable signs symbolize an intermediate between cardinal and fixed qualities. Mutable signs are also called ‘common’ because they have qualities common with both cardinal and fixed signs. These signs have more to do with thought and thinking. Many planets in mutable signs tend to produce a personality that is versatile and adaptable. They therefore often produce a two-sided nature which can lead to confusion.

The signs that comprise the *cardinal quality* are:

Aries, Cancer, Libra, Capricorn

The signs that comprise the *fixed quality* are:

Taurus, Leo, Scorpio, Aquarius

The signs that comprise the *mutable quality* are:

Gemini, Virgo, Sagittarius, Pisces

For Your Notes

As stated earlier, each sign of the zodiac is composed of a mixture of one quality and one element.

There are three zodiacal fire signs, three earth signs, three air signs, and three water signs. Because of this, the elements are often referred to as the triplicities.

The **fire** triplicity is: **Aries** **Leo** **Sagittarius**

The **earth** triplicity is: **Taurus** **Virgo** **Capricorn**

The **air** triplicity is: **Gemini** **Libra** **Aquarius**

The **water** triplicity is: **Cancer** **Scorpio** **Pisces**

Those natal horoscopes which have many planets in fire signs will show a personality that has a tendency to be more ardent and active, able to burn with excitement (so to speak).

Those natal horoscopes which have many planets in earth signs will indicate a person who is earthy, dependable and practical.

For Your Notes

Those natal horoscopes which have many planets in air signs will indicate a personality who stresses thinking, studying and communications (in some way or other).

Those natal horoscopes which have many planets in water signs will show a personality that is emotional, and who needs something to reflect upon. They are happiest when given shape by something or someone else because water has no shape of its own.



For Your Notes

Elements and Qualities

RECORDINGS 5 AND 6

FIRE SIGNS

Cardinal:	Aries	♈
Fixed:	Leo	♌
Mutable:	Sagittarius	♐

EARTH SIGNS

Cardinal:	Capricorn	♐
Fixed:	Taurus	♉
Mutable:	Virgo	♍

AIR SIGNS

Cardinal:	Libra	♎
Fixed:	Aquarius	♒
Mutable:	Gemini	♊

WATER SIGNS

Cardinal:	Cancer	♋
Fixed:	Scorpio	♏
Mutable:	Pisces	♓

For Your Notes

Elements and Qualities

RECORDINGS 5 AND 6

THE TRIPLICITIES (ELEMENTS)

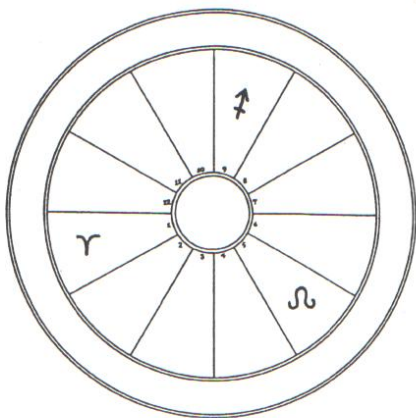

THE FIRE SIGNS:
Aries
Leo
Sagittarius

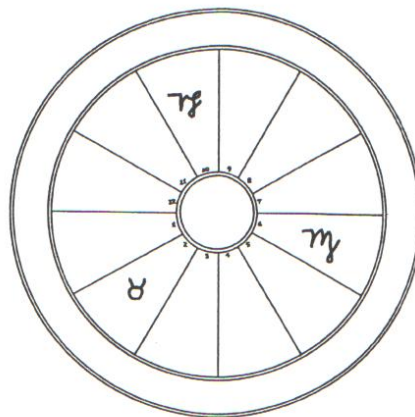

THE EARTH SIGNS:
Taurus
Virgo
Capricorn

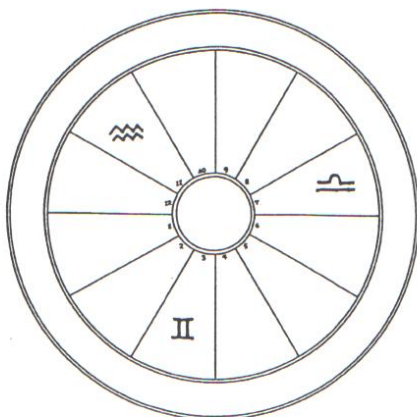

THE AIR SIGNS:
Gemini
Libra
Aquarius

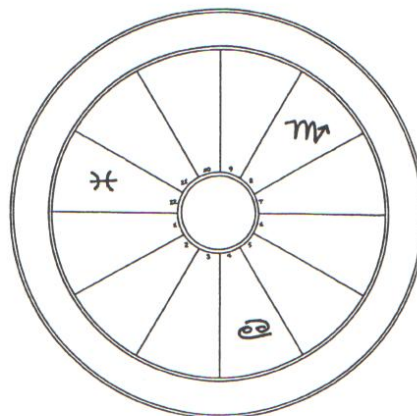

THE WATER SIGNS:
Cancer
Scorpio
Pisces

For Your Notes

Elements and Qualities

RECORDINGS 5 AND 6

THE QUADRUPPLICITIES (QUALITIES)

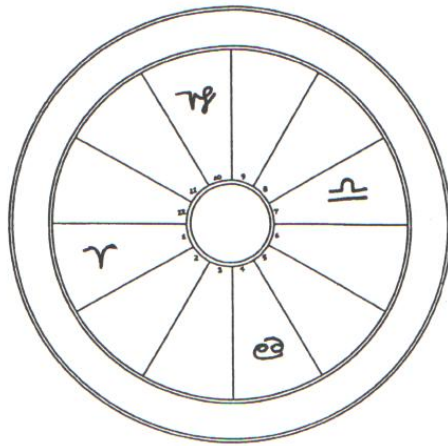

THE CARDINAL SIGNS:

Aries
Cancer
Libra
Capricorn

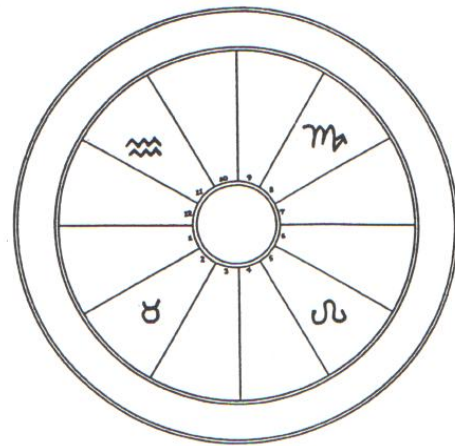

THE FIXED SIGNS:

Taurus
Leo
Scorpio
Aquarius

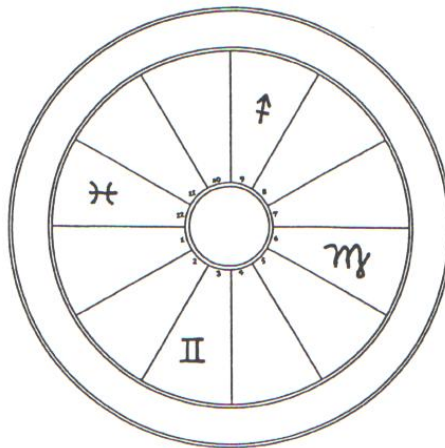

THE MUTABLE SIGNS:

Gemini
Virgo
Sagittarius
Pisces

For Your Notes

Finally, the elements mix and merge with the qualities, producing the 12 zodiacal signs in the following manner:

Cardinal	Fire	=	Aries	♈
Fixed	Fire	=	Leo	♌
Mutable	Fire	=	Sagittarius	♐
Cardinal	Earth	=	Capricorn	♑
Fixed	Earth	=	Taurus	♉
Mutable	Earth	=	Virgo	♍
Cardinal	Air	=	Libra	♎
Fixed	Air	=	Aquarius	♒
Mutable	Air	=	Gemini	♊
Cardinal	Water	=	Cancer	♋
Fixed	Water	=	Scorpio	♏
Mutable	Water	=	Pisces	♓

For Your Notes

If a person has a number of planets in a given sign or signs, that planet or planets will manifest the elements and the qualities of those signs.



For Your Notes

Study Guide

ELEMENTS AND QUALITIES

RECORDINGS 5 AND 6

Remember,

The *fire signs* are enthusiastic, creative, and optimistic.

The *earth signs* are dependable, material, stable or stubborn.

The *air signs* are mental, social, and intellectual.

The *water signs* are emotional, creative, and sensitive.

The *cardinal signs* produce people who are active; they do things; they initiate things.

The *fixed signs* are personality forces that try to conserve what is already in existence. They are stable and determined.

The *mutable signs* are concerned with communications, adaptability, and versatility.



For Your Notes

Study Guide

ELEMENTS AND QUALITIES

RECORDINGS 5 AND 6

Here are some additional key words for the qualities and elements:

THE FOUR ELEMENTS

Fire: Enthusiastic, energetic, creative, passionate, assertive, freedom-loving

Earth: Practical, grounded, sensual, reliable, stable, cautious

Air: Mental, communicative, social, detached, abstract, changeable

Water: Emotional, feeling, nurturing, hidden, sensitive

For Your Notes

THE THREE QUALITIES

Cardinal: Generating, initiating, active, direct, over-committed

Fixed: Concentrating, consolidating, focused, persevering, stubborn

Mutable: Distributing, connecting, adaptable, flexible, scattered

For Your Notes

KEY WORDS

QUALITIES

Cardinal:	Initiating Action – Aries, Cancer, Libra, Capricorn
Fixed:	Stabilizing Security – Taurus, Leo, Scorpio, Aquarius
Mutable:	Adapting to Learning – Gemini, Virgo, Sagittarius, Pisces

ELEMENTS

Fire:	Ideas and Enthusiasm – Aries, Leo, Sagittarius
Earth:	Material – Taurus, Virgo, Capricorn
Air:	Mental and Social – Gemini, Libra, Aquarius
Water:	Emotional and Soul – Cancer, Scorpio, Pisces



For Your Notes

Study Guide

DATA TO BE MEMORIZED FOR ELEMENTS AND QUALITIES

RECORDINGS 5 AND 6

- A) Each zodiacal sign contains 30 degrees, no more, no less.
- B) Each sign is made up of an element and a quality.
- C) There are four elements: fire, earth, air, and water.
- D) There are three qualities: cardinal, fixed, and mutable.
- E) Take your element and quality flash cards and learn the meaning of: fire, earth, air, and water; as well as the meaning of cardinal, fixed, and mutable.



For Your Notes

This is a blank page.

For Your Notes

8. The Zodiacal Signs in Detail

RECORDINGS 5 AND 6

This section can be read over quickly, and studied at a later date. The key things to be memorized are the planetary rulers of the signs. The date that the Sun enters each sign can be memorized at a later reading.

The following delineation of the zodiacal signs represents their pure qualities or attributes and does not directly relate to any particular planet when found in their sign.

The first sign of the zodiac is Aries.

♈ ARIES

Quality:	Cardinal
Element:	Fire
Planetary Ruler:	Mars/Pluto
Key Attribute:	Assertively

The Sun enters Aries on approximately the 21st day of March each year.

For Your Notes

The *positive* psychological attributes of the sign Aries are: fearless, courageous, constructive, spontaneous, quick-witted, self-assertive, intense, energetic, and offensive.

The *negative* psychological attributes of the sign Aries are: dictatorial, insecure, headstrong, impatient, selfish, argumentative, jealous, combative, and insubordinate.

You will note that the key words of Aries are similar to the key words of the planet Mars. This is as it should be for Mars rules Aries. Similarly, the key words of Aries also relate to the 1st house which is ruled by Mars. But, we will deal with that later.

The zodiacal sign Aries rules the face and head. Aries belongs to the fire triplicity and thus it has a mental quality that is rash, impulsive, inflammatory.

For Your Notes

♉ TAURUS

Quality:	Fixed
Element:	Earth
Planetary Ruler:	Venus
Key Attributes:	Possessively, enduringly

The Sun enters Taurus on approximately the 20th of April of each year.

Venus rules the sign of Taurus, and also Libra. Cardinal signs bring change into our lives. Taurus is fixed and will tend to hold the individual into whatever he is doing.

Taurus in its *positive* manifestation will produce traits that are expressed as steadfast, enduring, persistent, industrious, sympathetic, affectionate, magnetic, and reserved.

When the forces of Taurus are *negative*, it will produce qualities of being possessive, rigid, dogmatic, indulgent, stubborn, and lazy.

The sign of Taurus correlates to the 2nd house which relates to finances, possessions, and one's memory tract. It also correlates to the attributes of the planet Venus, its ruler. Taurus controls the neck and throat area.

For Your Notes

♊ GEMINI

Quality:	Mutable
Element:	Air
Planetary Ruler:	Mercury
Key Attribute:	Communicatively

The Sun enters Gemini on approximately May 21st of each year. Gemini is symbolized by the twins, because of its dual and fluctuating nature.

The *positive* psychological attributes of the sign Gemini can be expressed as: versatile, intellectual, expressive, inquiring, dual, sociable, liberal, and jack of all trades. It is the sign of the mediator.

The *negative* psychological attributes of the sign Gemini are: verbose, diffusive, nervous, shifty, superficial, vindictive, and indecisive. Gemini has a great deal in common with the 3rd house. They both relate to all forms of communication such as letter writing, messengers, inquiries, magazines, and rumors; brethren, neighbors, clerical workers, lecturing, debating, advertising, and reporting. It also relates to education, printing and merchandising, or the commercial field as a whole. It also has a correspondence to the attributes of Mercury, its ruler. The air triplicity represents the mental faculties of curiosity. These signs can best handle things in an abstract manner. They tend to be non-

For Your Notes

emotional in their expression. A mutable sign, Gemini, can adapt readily. It governs the arms, the collarbone, shoulders, the lungs, and nervous system.

♋ CANCER

Quality:	Mutable
Element:	Air
Planetary Ruler:	Mercury
Key Attributes:	Protectively, cautiously

The Sun enters Cancer on or about the 22nd of June of each year.

Cancer is a cardinal sign with a nature that takes action. It is outgoing, assertive, within a movement toward materiality. The *positive* psychological attributes of the sign Cancer are expressed by the following terms: tenacious, protective, conscientious, expressive, economical, intuitional, sympathetic, patient, retentive, maternal, romantic, and impressionable.

The *negative* psychological attributes of the sign Cancer are: fanciful, self-indulgent, changeable, possessive, touchy, frivolous, clannish, brooding, cautious, emotional, and imaginative. The Moon, ruler of Cancer, negatively positioned, tends to make one live in the past.

For Your Notes

Cancer relates to the breasts and stomach. It also relates very strongly to all the fluids of the body. Cancer is the symbol of motherhood and nourishing.

Cancer causes concern, worrying, and insecurity associated with romance and finances.

The qualities of zodiacal sign Cancer correspond to those of the 4th house and the Moon.

♌ LEO

Quality:	Fixed
Element:	Fire
Planetary Ruler:	Sun
Key Attributes:	Creatively, joyfully

The Sun enters the zodiacal sign of Leo on approximately July 23rd of each year.

The *positive* psychological attributes of Leo are: devoted, self-sacrificing, authoritative, courageous, dignified, magnanimous, creative, ardent, sincere, hospitable, generous, and hopeful.

For Your Notes

The *negative* psychological attributes of Leo are: vanity, snobbishness, secret meanness, favoritism, and easily flattered and misled.

Leo is associated with the heart and functions of the heart. Leo relates to those of the 5th house and the Sun.

♍ VIRGO

Quality:	Mutable
Element:	Earth
Planetary Ruler:	Mercury
Key Attributes:	Analytically, critically

The Sun enters the zodiacal sign of Virgo beginning approximately August 23rd of each year.

The *positive* psychological attributes of Virgo are: service, analytical, detailed, serious, thrifty, discriminative, concise, contemplative, studious, sanitary, methodical, and inquisitive.

The *negative* psychological attributes of Virgo are: non-sanitary, calculating, critical, indecisive, mercenary, fault-finding, skeptical,

For Your Notes

apprehensive, discontented, apathetic, inconsistent, unresponsive, and faddish.

Virgo governs the bowels. It also affects the nervous system. Worrying and concern are also quite common. Hypochondria and melancholia can be characteristic of this sign.

Virgo relates to health and hygiene; sickness, and service. The qualities of Virgo relate to Mercury and those of the 6th house.

 LIBRA

Quality:	Cardinal
Element:	Air
Planetary Ruler:	Venus
Key Attributes:	Harmoniously, unitedly

The Sun enters the zodiacal sign of Libra on approximately September 23rd of each year.

Libra is one of the most unique signs, if not the most unique for all zodiacal glyphs breathe except Libra, symbolized by a metal balance.

For Your Notes

The *positive* psychological characteristics of Libra are: neatness, affable, adaptable, harmonious, modest, gregarious, refined, gracious, and sociable.

The *negative* psychological characteristics of Libra are: aloof, vacillating, uncertain, hesitating, vain, and punctilious. Other tendencies are vanity and fence-straddling. Libra governs the kidneys, loins, and lower portions of the back.

Just as Aries symbolizes the natural birth of the year with its increasing strength as the Sun ascends northward, so Libra represents the descension or loss of vitality as the Sun moves southward. Thus, the Sun is weak in Libra, called its 'fall.'

The qualities of Libra relate to those of Venus and the 7th house.

For Your Notes

♏ SCORPIO

Quality:	Fixed
Element:	Water
Planetary Ruler:	Pluto/Mars
Key Attributes:	Penetratingly, passionately, secretively

The Sun enters the zodiacal sign Scorpio approximately October 24th of each year. Pluto and Mars have a strong affinity to both of the signs Scorpio and Aries.

The *positive* psychological characteristics of the zodiacal sign Scorpio are: energetic, aspiring, fearless, frank, regenerative, penetrating, and one-pointed.

The *negative* psychological characteristics symbolized by Scorpio are: secretive, strong-desiring, excessive, discordant, severe, cruel, caustic, sarcastic, vindictive, suspicious, jealous, blunt, dogmatic, and tyrannical.

Scorpio rules over the bladder and reproductive organs. The qualities of Scorpio relate to those of the planets Pluto and Mars as well as those of the 8th house.

For Your Notes

♐ SAGITTARIUS

Quality:	Mutable
Element:	Fire
Planetary Ruler:	Jupiter
Key Attributes:	Widely, deeply, philosophically

The Sun enters the zodiacal sign of Sagittarius approximately the 22nd of November of each year.

The *positive* psychological characteristics of Sagittarius are: idealistic, generous, honest, inspirational, prophetic, frank, cheerful, just, active, dependable, buoyant, philosophical, athletic, and magnanimous.

The *negative* psychological characteristics of Sagittarius are: impractical, indulgent, blunt, uncompromising, dogmatic, gullible, spendthrift, and self-righteous.

Sagittarius rules the liver, hips, thighs, and the blood.

People born under the zodiacal sign of Sagittarius or those with a predominance of planets in Sagittarius often have too many irons in the

For Your Notes

fire (much like Gemini); they need open spaces and physical exercises such as hiking, tennis, and horseback riding.

The qualities of Sagittarius relate to both those of Jupiter as well as the 9th house.

♄ CAPRICORN

Quality:	Cardinal
Element:	Earth
Planetary Ruler:	Saturn
Key Attributes:	Prudently, aspiringly, cautiously

The Sun enters the zodiacal sign Capricorn approximately the 22nd of December of each year.

The *positive* psychological characteristics are: industrious, efficient, conscientious, prudent, dependable, practical, particular, concentrative, self-controlled, diplomatic, profound, cautious, ambitious and self-disciplined.

For Your Notes

The *negative* psychological characteristics symbolized by Capricorn are: undemonstrative, miserly, suspicious, pessimistic, unsympathetic, exacting, materialistic, discontented, gloomy, depressive, and selfish; and rulership over discontentment, worrying, depression and despondency.

Capricorn rules the knees, joints, and the skin. The qualities of Capricorn correspond to both those of Saturn and the 10th house.

♊ AQUARIUS

Quality:	Fixed
Element:	Air
Planetary Ruler:	Uranus
Key Attributes:	Detachedly, scientifically, aloof

The Sun transits through the zodiacal sign Aquarius beginning on approximately the 20th of January of each year.

The *positive* psychological characteristics of Aquarius are: altruistic, persistent, progressive, inventive, universal, scientific, and cosmopolitan.

For Your Notes

The *negative* psychological characteristics of Aquarius are: eccentricity, exacting, faddish, exploitative, detached, unconventional, impersonal, unsympathetic, rebellious, radical, anxious, and skeptical.

Aquarius rules the ankles and calves. The qualities of Aquarius correspond to those of Uranus and the 11th house.

♋ PISCES

Quality:	Cardinal
Element:	Earth
Planetary Ruler:	Saturn
Key Attributes:	Nebulously, inspirational, confusedly

The Sun transits through the zodiacal sign Pisces approximately the 20th of February of each year.

The *positive* psychological characteristics of Pisces are: inspirational, intuitive, unselfish, sympathetic, compassionate, self-sacrificing, idealism, refinement, pure, romantic, idealistic, receptive, and sensitive.

For Your Notes

The *negative* psychological characteristics of the zodiacal sign Pisces are: negative, impractical, lethargic, hypersensitive, indecisive, moody, inferiority complex, and indulgent.

Pisces governs the feet as well as the psychic mechanisms. Those people with their Sun in Pisces or a predominance of planets therein, tend to be supersensitive to drugs and alcohol; they should totally abstain from them. The qualities of Pisces correspond to both Neptune and those of the 12th house.



For Your Notes

Study Guide

THE ZODIACAL SIGNS

RECORDING 6

Mnemonic Rule for the Signs

Aries ... Taurus ... Gemini ... Cancer ... Leo ... Virgo

AT God's Cave Loves Virgos

or

AT Georgia, Carol Loved Victor

Libra ... Scorpio ... Sagittarius ... Capricorn ... Aquarius ... Pisces

L S S C A P = LoSS-CAP



For Your Notes

Study Guide

DATA TO BE MEMORIZED
FOR THE ZODIACAL SIGNS IN DETAIL

RECORDINGS 5 AND 6

- A) Memorize now, the rulers of the signs.

- B) Memorize later, the dates the Sun enters each sign.



For Your Notes

This is a blank page.

For Your Notes

How to Become a Practicing Astrologer
Self-evaluation Test #5

In the place provided below, write one to three key words symbolizing the characteristics of each zodiacal signs:

1. The key words for Leo are

2. The key words for Gemini are

3. The key words for Scorpio are

4. The key words for Cancer are

5. The key words for Aquarius are

6. The key words for Aries are

For Your Notes

7. The key words for Taurus are

8. The key words for Pisces are

9. The key words for Sagittarius are

10. The key words for Libra are

11. The key words for Virgo are

12. The key words for Capricorn are



For Your Notes

RECORDINGS 7 AND 8

Please read pages 112-124
in *The Wisdom and Way of Astrology*

For Your Notes

This is a blank page.

For Your Notes

9. The Houses of the Horoscope

RECORDINGS 7 AND 8

The names of the houses are numbers. For example, the 1st house, 2nd house, 3rd house, etc. Sometimes the houses are called by their areas of manifestation. For example: The 1st house of personality, or the house of personality, the 2nd house of wealth, or the house of wealth, etc.

All houses stay in an orderly fashion, and they never move. The 1st house always starts on the left of the chart where nine on a clock would be, followed by the 2nd house below it.

The houses are the third fundamental area of study regarding astrology. The houses are segments or wedges of the horoscope which never change and symbolically tell you *where* the planets will manifest. The houses express the areas of our lives in which the urges will cause the events to occur. There are 12 houses.

If you refer to the diagram below, you will see the houses and their various relationships. The 1st house is always on the eastern horizon. The beginning of the 1st house is called the *Ascendant*. The beginning of any house is called a *cusp*.

For Your Notes

Again the houses are known and referred to by their number, such as the 1st house, the 2nd house, the 3rd house, and are numbered counter-clockwise. The houses never move. The 12 houses should not be confused with the 12 signs of the zodiac, which are always moving around the wheel of the chart.

There are three types of houses in the horoscope:

1. Angular houses
2. Succedent houses
3. Cadent houses



For Your Notes

The Houses

RECORDINGS 7 AND 8

THE HOUSES OF THE HOROSCOPE

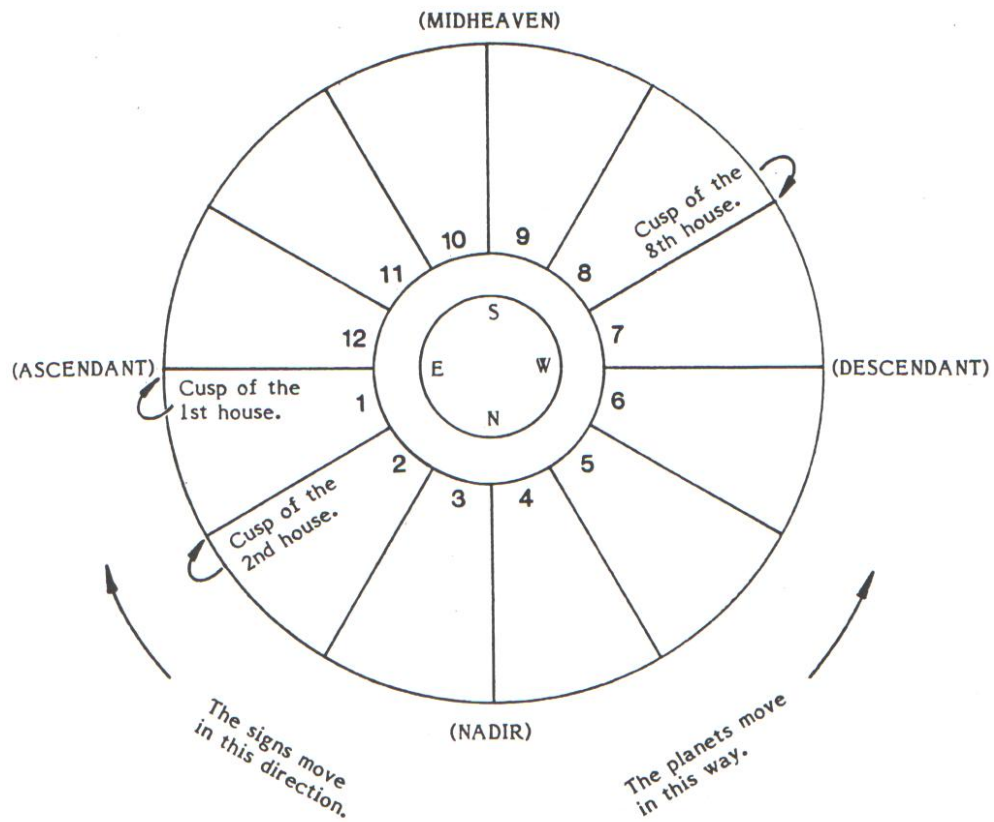

The houses don't move.

For Your Notes

The *angular* houses are the houses at the cardinal points of the compass: the 1st, 4th, 7th, and 10th houses. They correspond to the *cardinal* signs of the zodiac, in that planets in them manifest very strongly. Planets' urges in angular houses manifest most perceptibly.

The *succedent* houses are the 2nd, 5th, 8th, and the 11th houses. The planets in these houses do not manifest their urges strongly.

Planets in *cadent* houses manifest very weakly most of the time. The cadent houses are the 3rd, 6th, 9th, and 12th houses.

With regards to the houses, there are three more terms that need to be understood.

1. The *nadir* or low point is the cusp of the 4th house.
2. The *descendant* is the cusp of the 7th house.
3. The *Midheaven* or M.C. (standing for Medium Coeli) is the cusp of the 10th house.

For Your Notes

1st House

Here are the key words to memorize in relation to the 1st house: The personality, self-interests, physical appearance, and worldly outlook. Most are the same as the sign Aries.

The 1st house rules the personality. When a planet is positioned in the 1st house it indicates the type of worldly outlook the individual will have as well as his self-interests. It shows his natural disposition. It, also, has to do with temperament, physical build and appearance.

2nd House

Key words to memorize in relation to the 2nd house are: financial affairs, possessions, and memory tract. The 2nd house rules one's financial affairs and possessions. It reveals one's attitude toward money, as well as his worldly possessions. The 2nd house rules the capacity for comfort as well as how one gives and receives. It indicates possibilities of loss or gain of things. It also deals with one's memory tract.

3rd House

Key words to remember regarding the 3rd house are: brothers and sisters, short journeys, communications, writing, speech. The 3rd house concerns itself with brothers and sisters, neighbors, casual acquaintances, relationships and varying types of communication,

For Your Notes

including studying, mental inclinations, speech, writing, letters, books. It also relates to short journeys.

4th House

The key words to remember regarding the 4th house are: mother, home environment, attitudes regarding land, and conditions at the end of life. The 4th house rules the home environment and the mother, general conditions at the end of one's life, and conditions at the completion of events or things in one's life. It deals with attitudes regarding land, houses, and tradition.

5th House

Key words to remember regarding the 5th house are: love affairs, speculation, children, creativity, games, sports and entertainment. The 5th house rules hobbies, creativity, joys, pleasures, speculation, games, gambling, sports, and all types of entertainment and means of relaxation. Love affairs and the birth of children also come under the rulership of the 5th house.

6th House

The key words to remember concerning the 6th house are: sickness, servants, service, work, moods, and hygiene.

For Your Notes

The 6th house is the house of the three S's, meaning sickness, service, and servants. It is the house of work of all types and rules subordinates. It deals with hygiene, food, diet, and relates to the individual's health. It denotes small animals and clothing. This house also relates to negative moods thus, benefic planets are weaker in this house and malefic planets tend to produce a moodiness or pessimism.

NOTE: The first six houses have a relationship with the last six houses. Keeping this in mind will make memorizing the house meanings much easier.

For example:

The 1st house is self, the 7th is the spouse.

The 2nd house is your money, the 8th is others' money.

The 3rd house is short distance travel, the 9th house is long distance travel.

7th House

The key words to remember regarding the 7th house are: marriage, partnerships, general public, open enemies, and lawsuits.

The 7th house deals with partnerships. It rules over marriage, indicating one's husband or wife, business partners, or any other types of partnership. It includes the general public and how one relates to

For Your Notes

people in general. It also includes open enemies and opponents. The 7th house denotes lawsuits.

8th House

Key words to remember regarding the 8th house are: death, legacies, other people's money (including the spouse's), occult and astral experiences.

This is a house which relates to death and regeneration. It concerns itself with all matters of death which may be physical, mental, emotional, spiritual, or otherwise. It rules over legacies, wills, settlements, the money of the spouse, inheritances, and the money of other people. It also relates to astral experiences.

9th House

Key words to remember regarding the 9th house are: long journeys, higher education, philosophy, religion, and foreign countries.

Matters of long journeys are related to this house. It also rules foreign countries. It relates strongly to higher education of an inspirational nature, metaphysical and philosophical thinking, law, medicine, religion and spiritual tendencies. It denotes one's visions and dreams and as well as one's intuitional abilities.

For Your Notes

10th House

Key words to remember relating to the 10th house are: profession, occupation, father, authoritarian figures, government, ambitions, honor and fame. It is the house of beginnings, opposite the 4th (house of endings).

The 10th house indicates one's profession, his place in society and position in the world. It rules over one's employer, honor and fame, and promotions in one's profession. The 10th house is the house of pride. It relates to the individual's ambitions, his/her father, and authoritarian figures as well. Similarly, it relates to government. It is the house of destiny, in that it points to the potential fame and success of a person.

11th House

Here are some key words to learn regarding the 11th house: hopes, friends, associations, and aspiration.

The 11th house rules hopes and aspirations; it denotes one's ideals and his capacity for their realization. In this manner, the 11th house expresses the joys and pleasures of the spiritual and intellectual side of the individual. It rules over friends and associations of the individual, followers or dependents, clubs and club members, and societies.

For Your Notes

12th House

Here are some key words to remember concerning the 12th house: unexpected or unforeseen troubles, confinements and limitations, secret sorrows, hospitals, and secret enemies. And most important, self help.

The 12th house is the house of unexpected or unforeseen troubles, confinements and limitations, and secret sorrows of the individual. Herein lies the house of difficult tasks.

It is the house of secret enemies and betrayals. It is the house of self-sacrifice, self-undoing, and a movement from worldly to more spiritual goals. Thus, it is the house of introspection and self-examination. It rules over seclusion or exile. It rules over hospitals. It also denotes large animals as opposed to small animals of the 6th house. It is also the house of self-help.



For Your Notes

The Houses of the Horoscope

RECORDINGS 7 AND 8

More complete information on the houses:

1ST HOUSE ... KEY LIFE AREAS:

The personality

The worldly outlook

Self interests

Natural disposition

OTHER AREAS:

The physical body and its appearance

The stature and complexion of the body

The vitality and strength of the body

The body parts most susceptible to injury and/or illness

Early childhood impressions

The causes of financial loss and self-undoing

Aunts' and uncles' money (from parents' side, same sex as the native)

Residence and home life of the employer

Pleasures and love affairs attained through long journeys

The cause of death of servants or employees

Long journeys of one's children; their religious tendencies

Friends of brothers and sisters

For Your Notes

2ND HOUSE ... KEY LIFE AREAS:

Financial affairs

The memory tract

Possibilities of loss or gain of things

OTHER AREAS:

One's inner feelings and inner emotions

Holdings easily liquidated

One's financial vision

Capacity to lend or borrow money

One's resourcefulness

One's capacity for comfort

How one gives; how one receives

Limitations of one's brethren

Losses through brothers and sisters

Friends of the family

Self-undoing of brothers and sisters

Professional use of one's education

The honor or reputation of one's children

Long journeys in connection with one's work

The cause of death of the marriage partner

The cause of death of the business partner

Legacies or inheritances through the marriage partner

For Your Notes

Health and job prospects of brothers-in-law and sisters-in-law
Entertainment and/or pleasures derived from one's profession
Health conditions during long journeys

3RD HOUSE ... KEY LIFE AREAS:

Brothers and sisters
Short journeys
Mental inclinations
Neighbors

OTHER AREAS:

Casual acquaintances
One's enterprise; one's courage and daring
Receptivity to the ideas of others
One's will power
One's speech, hearing, and perceptions
The cause of the loss of property
The cause for moving the home
Those who live in one's home but who are not relatives
Publicity given to one's health or sickness
The reputation of one's employees or servants
Friends and associations of one's children
Confinements and limitations of the parent of the opposite sex
Long journeys of the spouse

For Your Notes

Religious attitudes of the spouse

Health conditions of the parent of the same sex

4TH HOUSE ... KEY LIFE AREAS:

The mother

The home environment

Attitudes regarding land

Attitudes regarding buildings and real estate

General conditions at the end of life

Conditions at the end of events (i.e., moods, attitudes, conditions, outcome at the ending of things such as relationships, jobs, divorce, moving, etc.)

OTHER AREAS:

The family tradition

Conditions in later life

The home environment, particularly the kitchen

The cause of losses through speculation

Limitations and confinements of one's children

Finances of one's brethren

Gains through writing or short journeys

Causes of sorrow through love affairs

Reputation and credit of business partners

The cause of death of brothers-in-law or sisters-in-law

For Your Notes

The health of one's stepchildren

The health of employees of friends

One's competitors in business

Inheritances from foreign lands

Cousins (children of uncles and aunts of the parent of the same sex)

Cooperation with government activities

Financial agreements

5TH HOUSE ... KEY LIFE AREAS:

Love affairs

Speculation

Children

Creativity

Games and gambling

Sports and entertainment

OTHER AREAS:

The cause of sorrow to aunts and uncles from the parent of the opposite
sex as the native

Friends of the spouse

Publicity given to one's death

Religious attitudes of one's grandchildren

Long journeys of one's grandchildren

Passions of the native

For Your Notes

Indulgences and dissipations

Ways and means of relaxation

Hobbies

Income from lands and real estate

The causes of ruptures of businesses

The causes of bankruptcy

The cause of the death of the parent of the same sex

Business competitors of friends

Services received when confined

One's bank or the place where one's wealth is stored

One's attitude toward responsibility

Short journeys of brethren

Mental resourcefulness of brothers and sisters

One's publication

6TH HOUSE ... KEY LIFE AREAS:

Sickness

Service

Servants

Small animals

Hygiene

Work

Living wealth, i.e., cows, cattle, grain

For Your Notes

OTHER AREAS:

Liabilities to sickness and/or accidents

The relationship to diet

Confinement of the spouse

Limitations through marriage

Limitations caused by partnership

Conditions under which one labors

Responsibility and irresponsibility in discharging obligations

Business in foreign countries

Food

Clothing

7TH HOUSE ... KEY LIFE AREAS:

Marriage

Open enemies

Partnerships

The general public

OTHER AREAS:

Description and attributes of the spouse

Loss through death

Friends in foreign countries

The reputation of one's employer

The reputation of the firm for which one works

Controversies, quarrels, and contested events

For Your Notes

Rivals, open enemies, and opponents
Things most difficult for one to achieve
The outcome of illness
The result of one's labors or services
Long journeys of one's friends
Religious attitudes of one's friends
Love affairs of one's brethren
Children of one's brethren
Entertainment while traveling short distances
The mentality of one's children
Later life conditions of the father in a female's chart
Later life conditions of the mother in a male's chart
Side trips while one is vacationing

8TH HOUSE ... KEY LIFE AREAS:

All matters concerned with death
Legacies
Astral experiences
Other people's money

OTHER AREAS:

The cause of one's death
The nature of one's death
Friends due to public life

For Your Notes

Friends due to one's business

Friends of the parent of the same sex as the native

Long journeys of aunts and uncles of the same sex

Undertakers, executioners

The doorway to the astral world

The doorway to the spirit world

Opponents to one's financing

Obstacles to financing

Magicians, warlocks, sorcerers, hypnotists, and obsessing entities

Gains through partnerships

Gains through marriage

Events or conditions at the end of the life of one's children

The outcome of lawsuits

Short trips connected with employment

9TH HOUSE ... KEY LIFE AREAS:

Long journeys

Higher education: philosophy, law, religion

Foreign countries

Dreams

Spiritual tendencies

OTHER AREAS:

Ritualism and ceremonialism

For Your Notes

The house of charity

The form of devotion

The type of church one will have a tendency to belong to

The results of one's creative energies

Unfoldment or gain from spiritual experiences

Unfoldment or gain from psychic experiences

Key method of expanding one's consciousness

Potential causes of financial difficulties

Sanitary conditions of the home

The care or negligence of property

Mentality of the spouse or business partners

Decisions reached in contested conflicts or disputes

The health of the parent of the opposite sex as the native

Pleasures derived from sports, parenthood, and love affairs

Grandchildren

End of life of uncles and aunts of parent of the opposite sex as the native

Losses or confinements in business or in one's occupation

The conditions of romance of one's children

10TH HOUSE ... KEY LIFE AREAS:

One's profession

The father and authoritarian figures

Government

For Your Notes

Honor and fame

The house of destiny

OTHER AREAS:

The realization of ambitions

The house of pride

Spiritual assets and opportunities

The rewards of karma

Sorrow, losses, or confinements of friends

Friends of uncles and aunts of the parent, the same sex as the native

Long journeys because of money matters

One's business tact

Retirement from worldly affairs

The cause of death of one's brethren

The health of one's children

The end of life of the spouse

Money made from long journeys or in foreign countries

Employer's opinion of the native

11TH HOUSE ... KEY LIFE AREAS:

Friends and associates

Aspirations, hopes, and dreams

Organizations

For Your Notes

OTHER AREAS:

One's likes and dislikes

Club members

Followers or dependents

Societies and organizations to which one belongs

Penalties, fines, etc., imposed upon the native

One's reputation regarding money matters

One's ability to overcome obstacles

How one will tend to use his money

Agreements with foreigners in foreign countries

Long journeys of one's brethren

Religious attitudes of one's brethren

Stepchildren

Attitude toward recreation and amusement of the spouse

Potential cause of the loss of property

The cause of death of the parent of the same sex

The health of uncles and aunts on the mother's side

12TH HOUSE ... KEY LIFE AREAS:

Unexpected or unforeseen trouble

Confinements, seclusion, or exile

Secret sorrows and secret enemies

Self-help and self-undoing

For Your Notes

Hospitals

Large animals

OTHER AREAS:

The symbol of the most difficult battles

The symbol of the hardest tasks

The symbol of misfortunes, doom, losses, woe, and troubles

The house of worries and worrying

Hospitals, jails, charitable institutions, prisons, and various asylums

The house of crime and criminals

The house of spies and espionage

The cause of the end of romantic affairs

The cause of death of one's children

One's residence when in foreign countries

The house of aunts and uncles of the parent, the same sex as the native

The symbol of things one must work out for himself

The way in which one relaxes; how one relaxes; how one sleeps

The house of introspection, self-examination, and inventory

Benefits from societies and organizations

The finances of friends

Gains through friends

One's occult mind

The closest point of contact to one's soul

For Your Notes

The Houses

RECORDINGS 7 AND 8

ANGULAR, SUCCEDENT, AND CADENT HOUSES

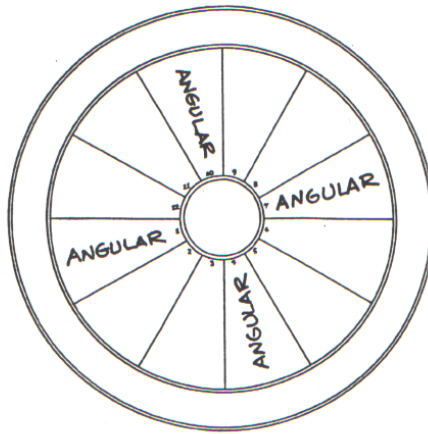

THE ANGULAR HOUSES:

1st House
4th House
7th House
10th House

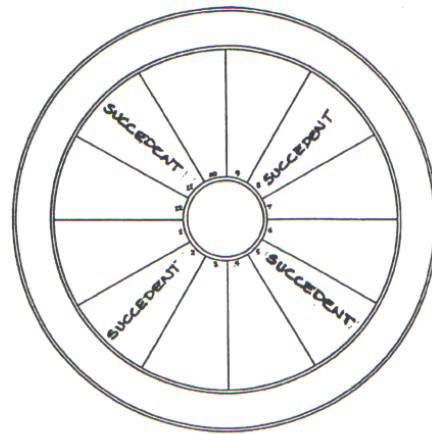

THE SUCCEDENT HOUSES

2nd House
5th House
8th House
11th House

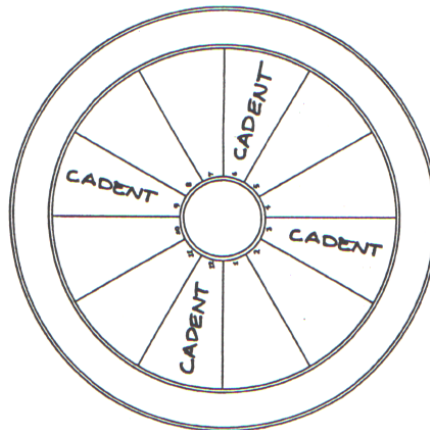

THE CADENT HOUSES

3rd House
6th House
9th House
12th House

For Your Notes

The Houses

RECORDINGS 7 AND 8

SAMPLE OF A FLAT CHART
(HOUSE CUSPS)

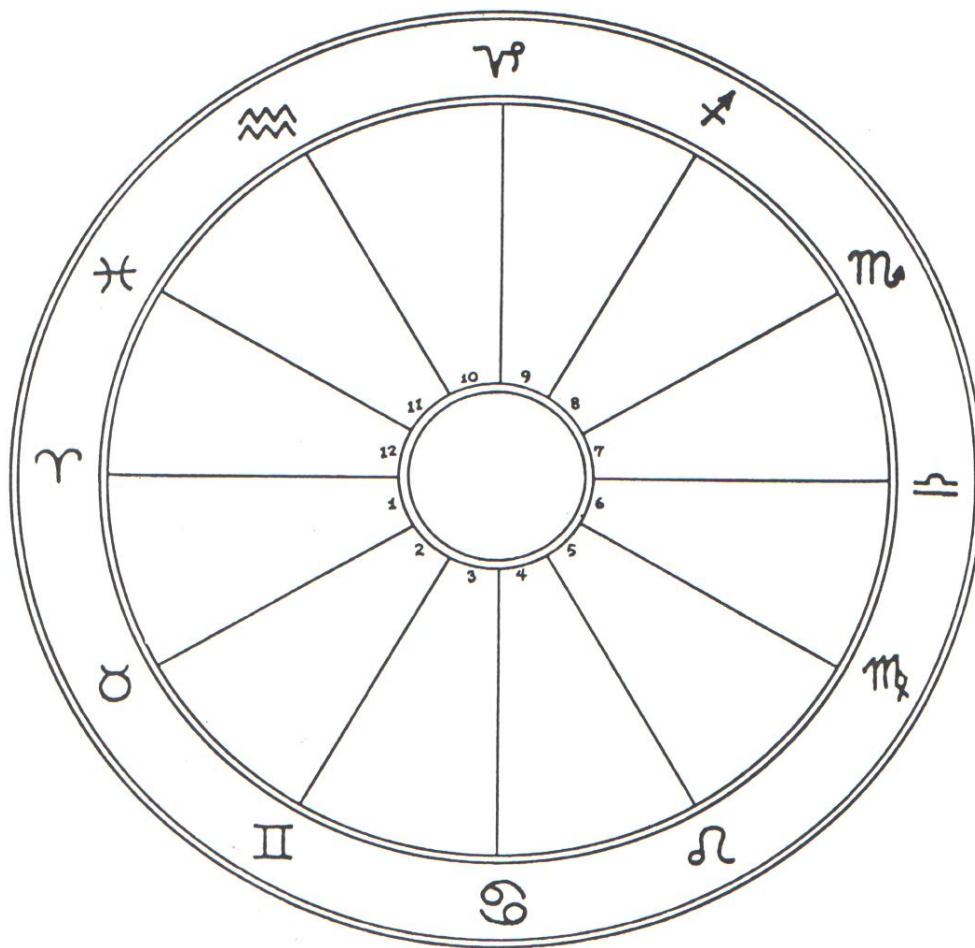

For Your Notes

The Houses

RECORDINGS 7 AND 8

The houses tell you where the forces will manifest.

Here are some additional key words:

- | | |
|-----------|--|
| 1st house | Your physical body, your personality, your view of life,
house of the self |
| 2nd house | House of money or possessions |
| 3rd house | Communications, brothers and sisters, neighbors, short
journeys, everyday mind |
| 4th house | Mother, your home environment, the end of things |
| 5th house | House of pleasures, joys, entertainments and
amusements, babies, creativity, speculation, God-
Consciousness |
| 6th house | House of the triple-S: sickness, servants, service; work |

For Your Notes

7th house House of partnerships: marriage or business, the not-self, the general public, open enemies

8th house House associated with death, dying and money of the dead, money of other people, the occult

9th house Long distance journeys, higher education, philosophy, religion, law, foreign countries, higher mind

10th house Father, government, authoritarian figures, the beginning of things, honors, career

11th house Hopes, friends, aspirations, clubs and societies

12th house House of self-undoing and self-help, confinements, hidden enemies, hospitals, prisons, large institutions, house of karma



For Your Notes

Study Guide

THE HOUSES

RECORDING 8

1. Personality
2. Wealth
3. Brethren
4. Mother/Home
5. Creativity/Children/Love
6. Service/Servants/Health
7. Partnerships
8. Legacies/Occult
9. Philosophy
10. Career
11. Friends/Hopes
12. Self-Help/Self-Confinement



For Your Notes

Study Guide

THE HOUSES

RECORDINGS 7 AND 8

Remember,

Angular houses are the 1st, 4th, 7th, and 10th.

Planets in angular houses tend to manifest physical energies. The more planets that are in angular houses, the more physically active the individual will be.

Angular houses have similarity to and correspond to the *cardinal signs*:
Aries, Cancer, Libra, Capricorn.

Succedent houses are the 2nd, 5th, 8th, and 11th.

Planets found in succedent houses tend to manifest or cause the native to engage in emotional activities directly relating to ego development activities.

Succedent houses have relationship and correspond to the *fixed signs*:
Taurus, Leo, Scorpio, Aquarius.

For Your Notes

Cadent houses are the 3rd, 6th, 9th, and 12th.

Planets found in *cadent houses* tend to manifest more in the direction of mental activity.

Cadent houses relate to and correspond to the *mutable signs*: *Gemini, Virgo, Sagittarius, Pisces*.



For Your Notes

Study Guide

DATA TO BE MEMORIZED FOR THE HOUSES IN THE ZODIAC

RECORDINGS 7 AND 8

- A) A house is *where* the force of a planet's urge will manifest.

- B) A *cusps* means the beginning of a house.

- C) Memorize a few key words for each of the 12 houses. Take your flash cards for the houses and cut them apart. Look at them a few times each day ... their meaning will easily settle into your mind.



For Your Notes

This is a blank page.

For Your Notes

How to Become a Practicing Astrologer
Self-evaluation Test #6

In the spaces provide below, write in one to three key words, indicating the meaning or life-areas associated with each corresponding house.

1. Key life areas for the 1st house are

2. Key life areas for the 9th house are

3. Key life areas for the 10th house are

4. Key life areas for the 4th house are

5. Key life areas of the 6th house are

6. Key life areas of the 3rd house are

For Your Notes

7. Key life areas of the 12th house are

8. Key life areas of the 7th house are

9. Key life areas of the 11th house are

10. Key life areas of the 8th house are

11. Key life areas of the 2nd house are

12. Key life areas of the 5th house are



For Your Notes

10. The Aspects in the Horoscope

RECORDING 9

The fourth and last major area in basic astrology is called the *aspects*. The aspects are important because they tell you whether a planet's force is positive or negative, as well as telling you the intensity of that positive or negative force.

An aspect is the measurement between two planets. (An aspect may also be a measurement between a planet and an important point within the horoscope like the Ascendant, or the Midheaven.)

The distance between planets, or between a planet and a place in the horoscope is measured in *degrees*. It is like saying that two buildings are so many blocks apart, or that two cities are so many miles apart. In astrology we say that two planets are so many *degrees* apart. The major aspects are: the conjunction, sextile, square, trine, and opposition.

For Your Notes

Here is a chart indicating the five major aspects:

Symbol	Aspect	Distance
♌	Conjunction	0 degrees
✳	Sextile	60 degrees
□	Square	90 degrees
△	Trine	120 degrees
♌♏	Opposition	180 degrees

Each of the five major aspects from the conjunction to the opposition has a special meaning all of its own.

♌ **The conjunction** symbolizes unity and power. A conjunction occurs when there is no distance between two planets. A planet in the same sign and degree as another planet is said to be in conjunction with each other. This brings out the strength of both planets. For this reason, as well as the fact that the conjunction is a symbol associated with the Sun, we say that it is a *power complex*: forceful, dynamic, crystallizing, and energizing.

For Your Notes

✳️ **The sextile:** Two planets are said to be sextile to each other when they are 60 degrees apart. A sextile is an *opportunity complex*. Planets in sextile aspect work in harmony with one another. The sextile is of the nature of the planet Venus.

□ **The square:** A square occurs when two planets are 90 degrees apart. The square is a *disruptive complex*. This disruptive force is usually caused by the individual himself, either consciously or subconsciously. The square has the nature of the planet Mars. It is usually considered negative owing to the discord arising from its manifestation. The conflicts and disturbances that arise by squares are very easy to observe in people's lives.

△ **The trine:** A trine occurs when two planets are 120 degrees apart. A trine is called a *luck complex*. The trine is always considered favorable and has the nature of the planet Jupiter, the greater benefic.

♋♏ **The opposition:** Two planets that are 180 degrees apart oppose each other and are said to be in opposition to one another. The opposition produces an *obstructive complex*. It has the nature of the Moon. It is considered inharmonious.

For Your Notes

Again, it is important to stress the fact that there are no evil aspects, although there are certainly harmonious and inharmonious aspects. Harmonious aspects emphasize what the average person considers positive, whereas inharmonious aspects tend to bring out the less desired influences.

The beginning student of astrology should note that so-called inharmonious aspects usually bring fame in worldly ventures, accomplishments, and attainments. On the other hand, individuals with an abundance of harmonious aspects are more content with life, not striving for external success.

The best chart is a chart filled with both harmonious and inharmonious aspects (particularly to the same planet). This will give drive (the inharmonious aspect), as well as good fortune (harmonious).

There are also applying and separating aspects. An applying aspect occurs when a faster moving planet is approaching an aspect to a slower moving planet. As an example, if the Moon were at 5 degrees of Aries and the Sun were 6 degrees of Aries, because the Moon is faster moving and is moving into the Sun, it is an applying aspect. An applying aspect is much stronger than a separating aspect.

For Your Notes

A separating aspect occurs when a faster moving planet has moved beyond or has passed an exact aspect to a slower moving planet. As an example, if the Moon were 6 degrees of Aries and the Sun were 5 degrees of Aries. Because the Moon is faster moving than the Sun and has moved passed the exact aspect to the Sun, it is a separating aspect. The separating aspect is weaker than an applying aspect.



For Your Notes

Orbs of Influence

Rarely, if ever, are two planets in exactly the same degree. Therefore, an orb of influence is allowed. This means that two planets can form an aspect even though their distance from one another is not the same exact degree of each other. For example, the Sun in 5 degrees of Aries and the Moon in 5 degrees of Aries are in exact conjunction. But an orb of influence of a few degrees is allowed, consequently you may have the Sun in 5 degrees of Aries and the Moon in 10 degrees of Aries, and they will still be in conjunction. This means that the Sun in 15 degrees of Pisces will be trined any planet from 8 degrees to 22 degrees of Cancer or Scorpio, if it is angular or on a cusp.

Allow approximately 5 to 7 degrees orb for the Sun, the Moon, and the larger planets: Jupiter and Saturn. When these planets are angular, or on a cusp, the orb increases from 5 degrees to 7 degrees.

Allow approximately a 3- to 4-degree orb for Uranus and Neptune. When these planets are angular, or on a cusp, the orb increases from 3 degrees to 4 degrees.

Allow an orb of 3 degrees for the smaller planets, Mercury, Venus, Mars, or Pluto unless they are on a cusp or angular. Then increase it by 1/2 degree.

For Your Notes

It is important that you recognize and keep in mind that the closer the orb, the stronger the force of the aspect; the wider the orb, the weaker its force-field!

When you first begin to work with charts, it is a good idea to draw a line between the various aspecting planets and mark the symbol of the aspect on the line near the faster moving planet.

At first, the computation of the aspects seems to be confusing and difficult, but with a little patience and practice, you will be able to easily tell the aspects at a glance.

Whenever you look at an aspect, a series of thoughts should be thought about:

1. Is the aspect harmonious or inharmonious?
2. Is the orb wide, narrow, or exact?
3. Is the aspect forming or past?
4. Is either planet in a cardinal sign?
5. Is either planet in an angular house?
6. Is either planet retrograde?

For Your Notes

Retrograde planets are sometimes found in a horoscope. This means the planet appears to be moving backwards in the heavens. Planets that are retrograde vibrate, and deliver, less positive energy. You can tell a planet is retrograde by looking into an ephemeris. It will be marked with an 'R.' An ephemeris is a book of the planets' daily positions. Below, see a page from an ephemeris calculated for noon at Greenwich. This is what an ephemeris looks like:

**SIMPLIFIED SCIENTIFIC
EPHEMERIS OF THE PLANETS' PLACES**
Calculated for Mean Noon at Greenwich
February, 1954
New Moon, February 3, 3:54 P.M. in α 14° 18'
Longitude of the Planets

Day	☉	☿	♁	♂	♃	♅	♁	♁	♁	♁	♁	♁
	°	'	"	°	'	"	°	'	"	°	'	"
M 1	12 06 11	12 43 24	30 14 11	9 08 16	33 25 19	20 11 25	59 23 05					
T 2	13 07 05	13 58 26	13 27 54	9 11 16	32 25 53	20 09 25	59 23 02					
W 3	14 07 58	15 14 27	55 11 58	9 13 16	31 26 27	20 07 25	59 22 59					
T 4	15 08 50	16 29 29	35 26 20	9 15 16	29 27 01	20 04 25	58 22 55					
F 5	16 09 40	17 45 13	14 10 55	9 16 16	27 27 35	20 02 25	58 22 52					
S 6	17 10 30	19 00 2 51	25 35 9	9 16 16	26 28 09	20 00 25	58 22 49					
S 7	18 11 18	20 16 4 26	10 13 9	9 17 16	26 28 43	19 58 25	58 22 46					
M 8	19 12 04	21 31 5 57	24 44 9	9 17 16	25 29 17	19 56 25	58 22 43					
T 9	20 12 49	22 52 7 24	9 03 9	9 18 16	25 29 50	19 54 25	58 22 40					
W 10	21 13 32	24 02 8 47	23 07 9	9 18 16	25 0 24	19 52 25	57 22 36					
T 11	22 14 14	25 18 10 05	6 56 6	9 19 16	25 0 57	19 50 25	57 22 33					
F 12	23 14 53	26 33 11 17	20 28 9	9 19 16	26 1 31	19 48 25	57 22 30					
S 13	24 15 31	27 48 12 23	3 54 6	9 19 16	26 2 04	19 46 25	57 22 26					
S 14	25 16 07	29 04 13 22	16 50 9	9 20 16	27 2 37	19 44 25	56 22 23					
M 15	26 16 42	30 19 14 12	29 41 9	9 20 16	28 3 10	19 42 25	56 22 20					
T 16	27 17 16	1 35 14 54	12 51 9	9 20 16	29 3 43	19 40 25	55 22 17					
W 17	28 17 48	2 50 15 26	24 51 9	9 20 16	30 4 15	19 38 25	55 22 15					
T 18	29 18 19	4 05 15 49	7 10 9	9 20 16	32 4 48	19 36 25	54 22 12					
F 19	30 18 47	5 20 16 03	19 20 9	9 20 16	34 5 20	19 34 25	54 22 08					
S 20	1 19 19	6 35 16 06	1 23 9	9 19 16	36 5 53	19 32 25	53 22 05					
S 21	2 19 40	7 50 15 59	13 19 9	9 19 16	38 6 25	19 31 25	53 22 02					
M 22	3 20 04	9 05 15 42	25 12 9	9 18 16	41 6 57	19 29 25	52 21 58					
T 23	4 20 27	10 19 15 16	7 04 9	9 18 16	44 7 29	19 27 25	51 21 55					
W 24	5 20 49	11 34 14 41	18 58 8	9 17 16	46 8 01	19 26 25	50 21 52					
T 25	6 21 09	12 49 13 57	1 01 8	9 17 16	49 8 33	19 24 25	49 21 48					
F 26	7 21 28	14 04 13 07	13 15 8	9 16 16	52 9 05	19 23 25	49 21 45					
S 27	8 21 45	15 19 12 12	25 46 8	9 16 16	55 9 37	19 21 25	48 21 42					
S 28	9 22 01	16 34 11 12	8 39 8	9 15 16	59 10 08	19 20 25	47 21 39					

Pluto, Longitude, February 1, 1954, α 24° 06'

**SIMPLIFIED SCIENTIFIC
EPHEMERIS OF THE PLANETS' PLACES**
Calculated for Mean Noon at Greenwich—February, 1954
Full Moon, February 17, 7:19 P.M., in α 28° 36'
Declination of the Planets

D	S. T.	Dec	D	☉	☿	♁	♂	♃	♅	♁	♁	♁
	H. M. S.	°	'	°	'	"	°	'	"	°	'	"
1	20 44 38	23 35	2	16 53 17	49 14 01	12 12 22	24 18 17	22 25 8	28			
2	20 48 35	20 14	4	16 18 17	07 12 35	12 12 22	24 18 34	22 26 8	27			
3	20 52 31	15 39	6	15 41 16	23 11 07	12 12 22	24 18 50	22 26 8	27			
4	20 56 28	10 06	8	15 04 15	37 9 58	12 13 22	24 19 06	22 27 8	27			
5	21 00 24	3 55	10	14 26 14	49 8 10	12 13 22	25 19 21	22 28 8	26			
6	21 04 21	2N29	12	13 46 14	00 6 48	12 13 22	25 19 36	22 28 8	26			
			14	13 06 13	09 5 32	12 12 22	25 19 50	22 29 8	25			
7	21 08 17	8 43	16	12 25 12	16 4 27	12 12 22	26 20 04	22 29 8	25			
8	21 12 14	14 27	18	11 43 11	23 3 37	12 12 22	27 20 17	22 30 8	24			
9	21 16 10	19 18	20	11 00 10	28 3 03	12 11 22	27 20 30	22 30 8	24			
10	21 20 07	22 58	22	10 17 9	32 2 48	12 10 22	28 20 42	22 31 8	23			
11	21 24 04	25 14	24	9 33 8	35 2 53	12 09 22	29 20 54	22 31 8	22			
12	21 28 00	25 58	26	8 49 7	37 3 17	12 09 22	30 21 06	22 32 8	21			
13	21 31 57	25 11	28	8 04 6	38 3 56	12 07 22	31 21 17	22 32 8	21			
14	21 35 53	23 01										
15	21 39 50	19 42	D	☉	☿	♁	♂	♃	♅	♁	♁	♁
16	21 43 46	15 30		° N	° S	° S	° N	° S	° N	° N	° N	
17	21 47 43	10 43	2	0 21 1	13 1 19	2 29 0	22 0 58	0 29 1	43			
18	21 53 36	5 34	4	2 49 1	16 1 02	2 29 0	22 0 58	0 29 1	43			
19	21 55 36	0 17	6	4 37 1	18 0 41	2 30 0	21 0 57	0 29 1	43			
20	21 59 33	4S56	8	5 14 1	19 0 24	2 30 0	21 0 56	0 29 1	43			
			10	4 34 1	21 0N08	2 31 0	20 0 55	0 29 1	44			
21	22 03 29	9 56	12	2 52 1	23 0 34	2 31 0	20 0 54	0 29 1	44			
22	22 07 26	14 38	14	0 38 1	24 1 06	2 31 0	20 0 53	0 29 1	44			
23	22 11 22	18 36	16	1S40	1 25 1 38	2 32 0	19 0 52	0 29 1	44			
24	22 15 19	21 56	18	3 34 1	26 2 14	2 32 0	19 0 51	0 29 1	44			
25	22 19 15	24 21	20	4 47 1	27 2 37	2 33 0	18 0 50	0 29 1	44			
26	22 23 12	25 40	22	5 09 1	27 3 03	2 33 0	18 0 48	0 29 1	44			
27	22 27 08	25 45	24	4 38 1	27 3 23	2 34 0	18 0 46	0 29 1	44			
			26	3 18 1	26 3 31	2 34 0	17 0 44	0 29 1	44			
28	22 31 05	24 27	28	1 17 1	26 3 42	2 35 0	17 0 43	0 29 1	44			

Pluto, Declination, February 1, 1954, N. 22° 24'—Latitude N. 9° 49'

For Your Notes

NOTE: In astrology, hours of time are symbolized by *h* or by *hrs*.

Minutes of arc or minutes of time are symbolized by *m*. Minutes of arc are written as a small *m* or single apostrophe (').

Seconds of a clock are written as *s*. Seconds of arc are also written as a double apostrophe (").

Degrees of arc are written as *Deg.* or as a little circle (°).

You should know that 60 seconds of arc equals 1 minute and that 60 minutes equals 1 degree.



For Your Notes

The Seven Aspects

RECORDING 9

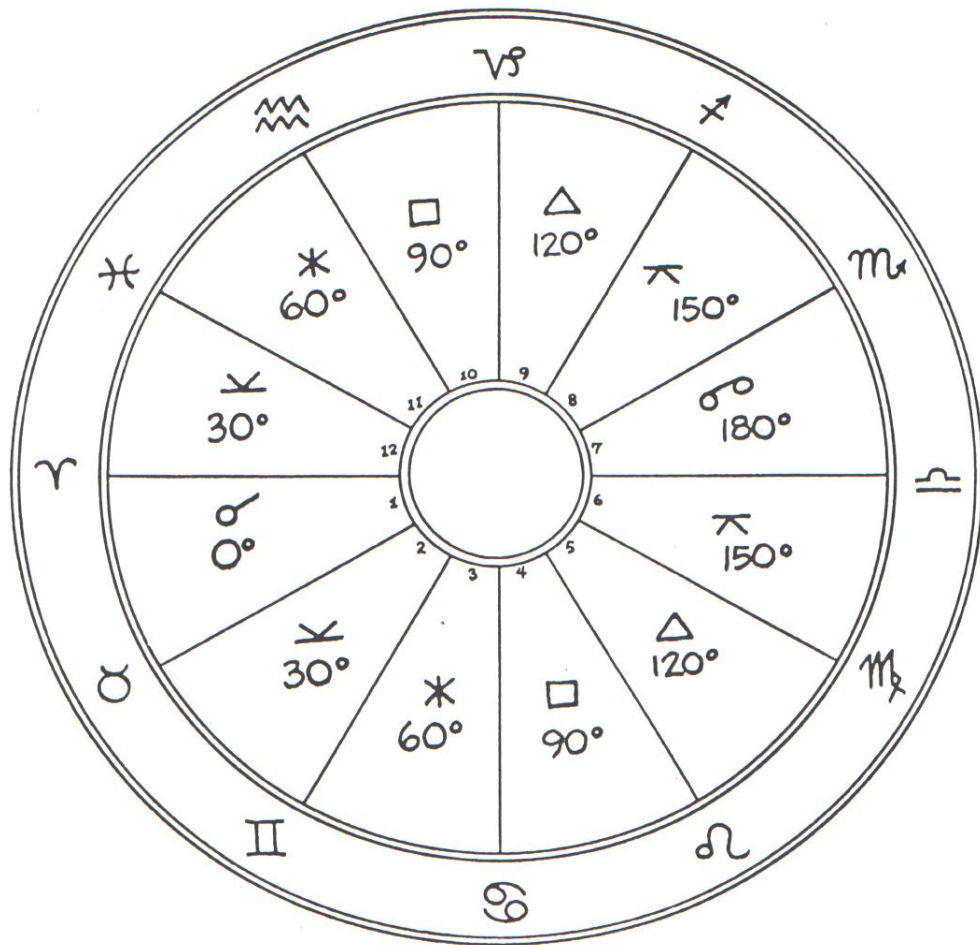

For Your Notes

Masculine and Feminine Signs
Positive and Negative Signs

RECORDING 9

The planets existing in masculine signs tend to be extroverted in their activity.

The planets existing in feminine signs tend to be introverted in their activity.

Aries (masculine)	+	Libra (masculine)	+
Taurus (feminine)	-	Scorpio (feminine)	-
Gemini (masculine)	+	Sagittarius (masculine)	+
Cancer (feminine)	-	Capricorn (feminine)	-
Leo (masculine)	+	Aquarius (masculine)	+
Virgo (feminine)	-	Pisces (feminine)	-

Masculine or extroverted signs are the Air signs and the Fire signs.

Feminine or introverted signs are the Earth signs and the Water signs.



For Your Notes

Masculine and Feminine Signs Positive and Negative Signs

RECORDING 9

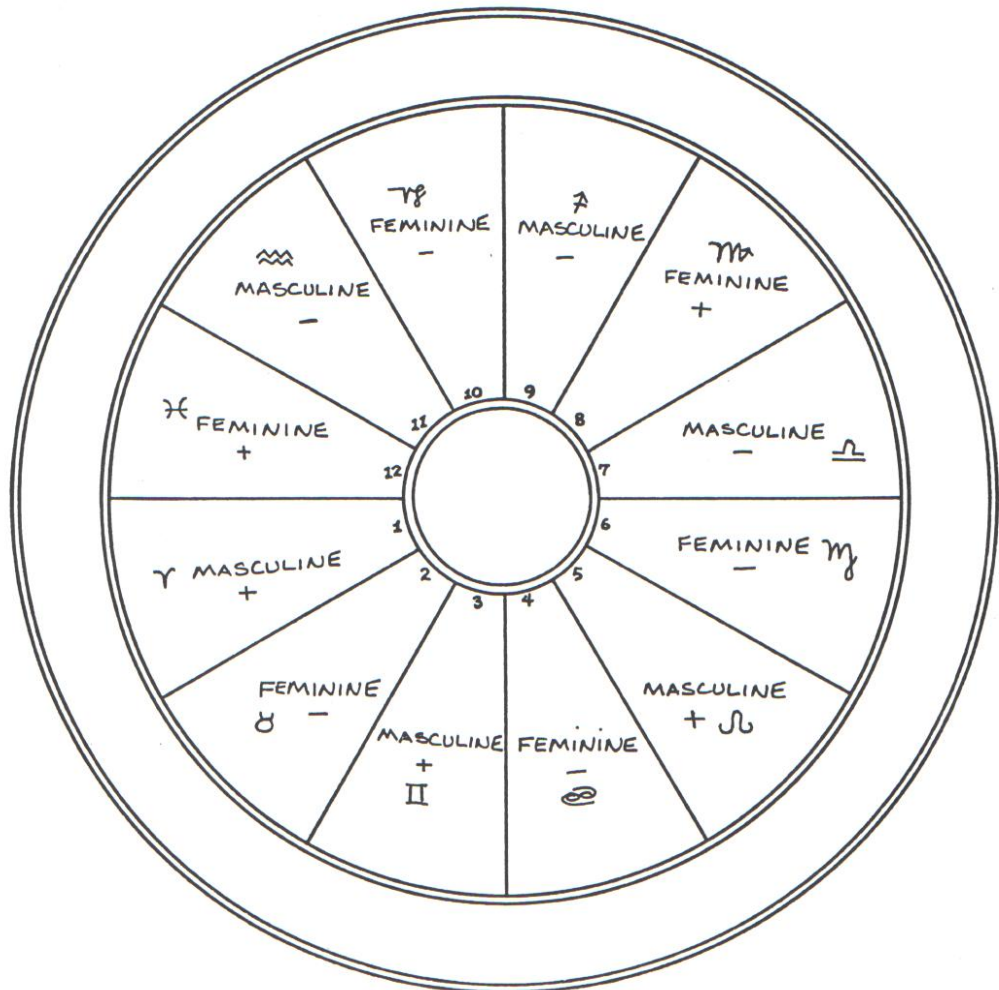

For Your Notes

Aspects

RECORDING 9

AN OVERVIEW OF THE HOROSCOPE

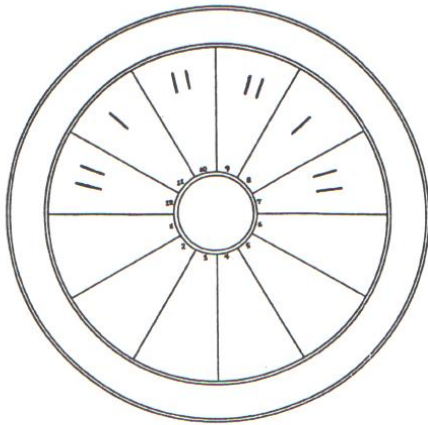

All the planets located above the horizon

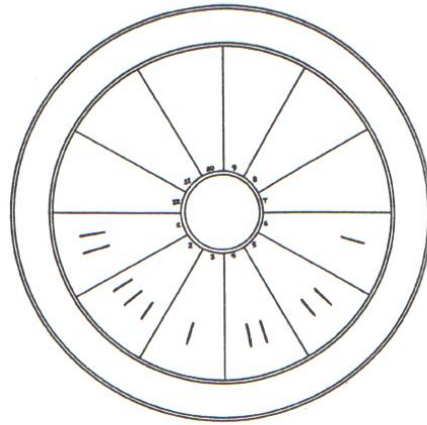

All the planets located below the horizon

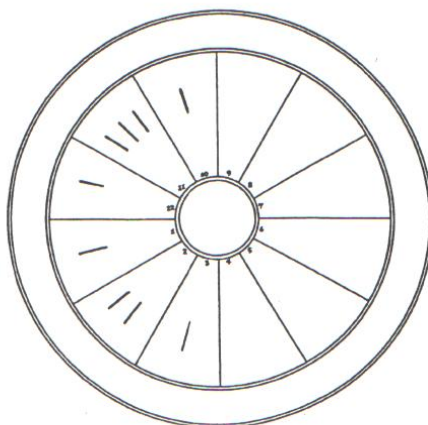

All the planets located on the eastern side of the chart

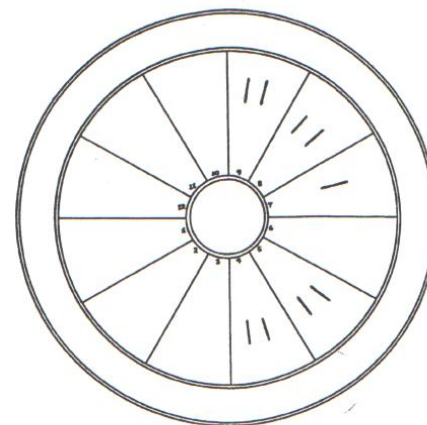

All the planets located on the western side of the chart

For Your Notes

Aspects

RECORDING 9

AN OVERVIEW OF THE HOROSCOPE, CONTINUED

When all of the planets are above the horizon in Houses 7-12, the individual will tend to be more extroverted, aggressive, and materialistic. Public life and career are most important to the person. These individuals function in life harmoniously. Fame will manifest.

When all of the planets are below the horizon, the person will tend towards being more introverted with private life important.

If *most* of the planets are above the horizon, the person will tend toward being more extroverted with public life important. If most of the planets are below the horizon, the person will tend to be more introverted with private life more important.

Exception: When all the planets are above the horizon except one planet which is below the horizon, the person will be driven toward that single planet called a “singleton” and the person will tend to be more introverted and the private life more vital.

For Your Notes

When all of the planets are on the eastern (or left) side of the chart (houses 10 through 3), the individual will be in control of his own destiny. He will be aggressive, dynamic and forceful.

When all the planets are on the western (or right) side of the chart (houses 4 through 9), the person's destiny lies in the hands of other people. The person will be more introverted and less assertive. He will deal more with reactions to things rather than taking action.

If most of the planets are to the east and few toward the west, the person will tend to have greater control of his destiny. If most of the planets are to the west and few toward the east, the person will tend to be more introverted and his destiny will be in the hands of others.

Exception: When nine planets are to the east and one planet is to the west, the singleton takes over and because of this one planet, wherever it is, the individual's destiny will tend to be in the hands of others.

If nine planets are to the west and one planet is to the east, that person will tend to control his own destiny.



For Your Notes

Aspects and Symbols

RECORDING 9

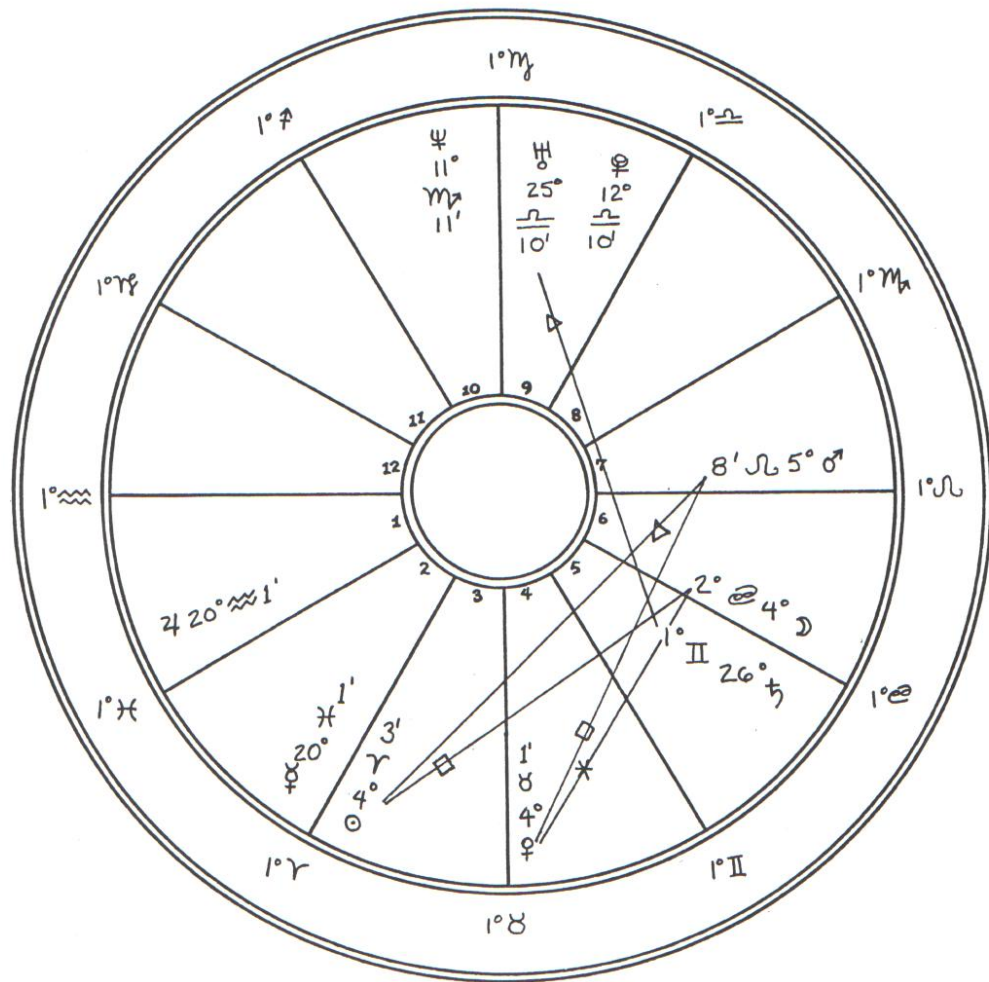

















For Your Notes

Study Guide

THE ASPECTS

RECORDING 9

A MORE COMPLETE SUMMARY OF THE MAJOR ASPECTS

<u>Aspect</u>	<u>Distance Apart</u>	<u>Symbol</u>	<u>Type of Force</u>	<u>+ or -</u>	<u>Symbolical Planet</u>
Conjunction	0°		Power	+ or -	
Sextile	60°		Opportunity	+	
Square	90°		Disruption	--	
Trine	120°		Luck	++	
Inconjunct (Quincunx)	150°	 or 	Stress	-	
Opposition	180°		Opposing	-	
Parallel	0° N. or S.		Power or opposing	+ or -	 or 

Inconjunct:

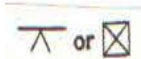

The inconjunct is a not so minor, minor aspect and symbolizes stress, health problems, and for some people, guilt, depending on the house in which it is found.

For Your Notes

Parallel of Declination: P

Planets found within 1 degree of the exact same declination are considered to be parallel. If both planets are on the same declination (either north or south), i.e., both north or both south, it is called a Parallel of Declination. If one planet is north and the other south it is sometimes referred to as a Contraparallel. The Parallel acts like a long lasting conjunction. The Contraparallel acts like a long lasting opposition.



For Your Notes

Study Guide

DATA TO BE MEMORIZED FOR THE ASPECTS IN THE HOROSCOPE

RECORDING 9

A) The six major aspects and their distance are:

Aspect	Distance	Symbol	Type of Force
Conjunction	0 degrees	♌	Power force
Sextile	60 degrees	✳	Opportunity force
Square	90 degrees	□	Disruptive force
Trine	120 degrees	△	Good luck force
Opposition	180 degrees	♌♏	Opposing force

B) What is the orb of influence of each planet? Read that section again and write each down on a sheet of paper.

C) Use your aspect flash cards and study them daily.



For Your Notes

This is a blank page.

For Your Notes

How to Become a Practicing Astrologer
Self-evaluation Test #7

Fill in each answer with the appropriate symbol or words:

1. What is the meaning of an orb of influence?

2. The symbol for a trine is

3. The symbol for a square is

4. Which planets allow for a 7 degree orb?

5. The symbol for an opposition is

6. The symbol for a sextile is

For Your Notes

7. The symbol for a conjunction is

8. What planets allow for a 3 degree orb?



For Your Notes

How to Become a Practicing Astrologer
Self-evaluation Test #8

Please fill in the spaces below with the appropriate words or key concepts.

1. A conjunction is known as a _____ complex, therefore the planets involved in a conjunction have the following characteristics:

2. The trine is known as a _____ complex, therefore planets involved in a trine have the following characteristics:

For Your Notes

3. A square is known as a _____ complex, therefore the planets involved in a square have the following characteristics:

4. A sextile is known as an _____ complex, therefore the planets involved in a sextile have the following characteristics:

For Your Notes

5. An opposition is known as an _____ complex, therefore the planets in an opposition have the following characteristics:



For Your Notes

RECORDING 10

Please read pages 144–149 and 176–180
in *The Wisdom and Way of Astrology*

For Your Notes

RECORDING 11

Please read pages 150–154 and 181–185
in *The Wisdom and Way of Astrology*

For Your Notes

RECORDING 12

Please read pages 155–159 and 186–190
in *The Wisdom and Way of Astrology*

For Your Notes

RECORDING 13

Please read pages 160–165 and 191–196
in *The Wisdom and Way of Astrology*

For Your Notes

RECORDING 14

Please read pages 166–170 and 197–201
in *The Wisdom and Way of Astrology*

For Your Notes

RECORDING 15

Please read pages 171–175 and 202–206
in *The Wisdom and Way of Astrology*

For Your Notes

RECORDING 16

Please read pages 207–211
in *The Wisdom and Way of Astrology*

For Your Notes

RECORDING 17

Please read pages 211–216
in *The Wisdom and Way of Astrology*

For Your Notes

RECORDING 18

Please read pages 216–222
in *The Wisdom and Way of Astrology*

For Your Notes

RECORDING 19

Please read pages 222–230
in *The Wisdom and Way of Astrology*

For Your Notes

RECORDING 20

Please read pages 230–237
in *The Wisdom and Way of Astrology*

For Your Notes

RECORDING 21

Please read pages 237–247
in *The Wisdom and Way of Astrology*

For Your Notes

This is a blank page.

For Your Notes

How to Become a Practicing Astrologer
Self-evaluation Test #9

1. Which zodiacal sign is not alive, does not breathe?

2. Is astrology an art or a science?

3. What are the three air signs?

4. The key characteristics of a person with a predominance of cardinal signs are _

5. A circle always contains how many degrees? _____

6. What are the four cardinal signs?

For Your Notes

7. What two “planets” are referred to as the luminaries?

8. Define astrology

9. Key characteristics of a person with a predominance of planets in fire signs are:

10. What is an ephemeris?

For Your Notes

11. Key characteristics of a person with a predominance of planets in mutable signs are:

12. Do the signs move clockwise or counterclockwise over the horizon? _____

13. How many signs of the zodiac are there? _____

14. Key characteristics of a person with a predominance of planets in air signs are:

15. A sign always consists of how many degrees? _____

For Your Notes

16. Key characteristics of a person with a predominance of planets in fixed signs are:

17. What are the three fire signs?

18. Do the planets move clockwise or counterclockwise?

19. What are the four mutable signs?

20. What are the three water signs?

For Your Notes

21. Key characteristics of a person with a predominance of planets in water signs are:

22. Key characteristics of a person with a predominance of planets in earth signs are:

23. What are the four fixed signs?

24. What are the three earth signs?

For Your Notes

25. What is a Table of Houses?



For Your Notes

RECORDING 22

Please read pages 248–256
in *The Wisdom and Way of Astrology*

For Your Notes

RECORDINGS 23-24

Please read pages 113 and 257-261
in *The Wisdom and Way of Astrology*

For Your Notes

RECORDINGS 23-24

The Houses of the Horoscope

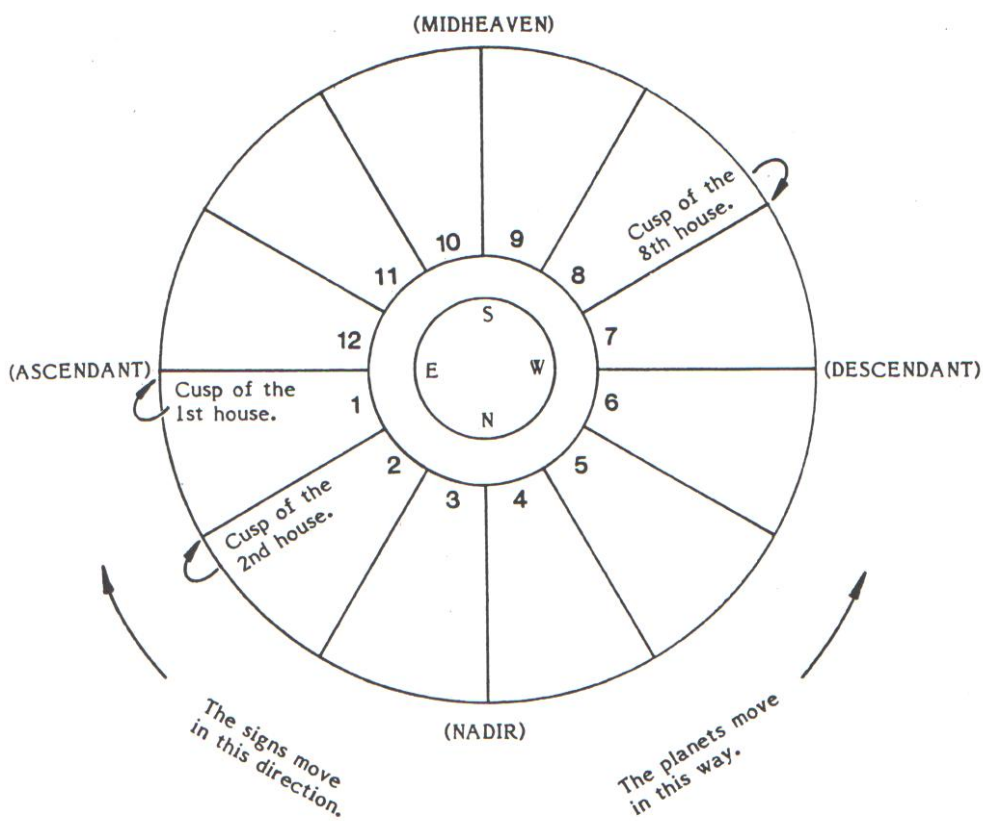

The houses don't move.

For Your Notes

Chart Patterns – RECORDINGS 23-24

SPRAY

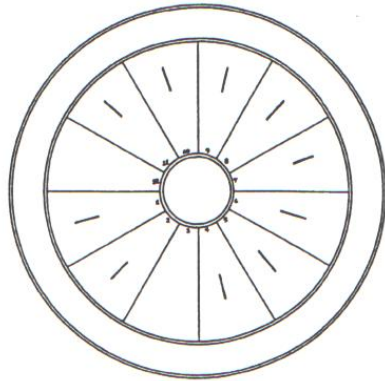

SEE-SAW

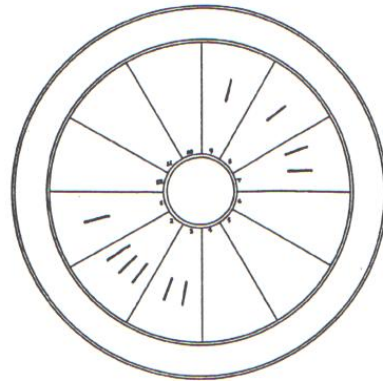

LOCOMOTIVE

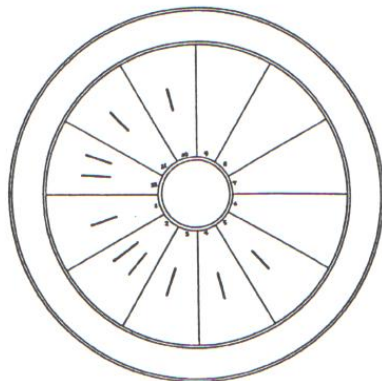

BUNDLE

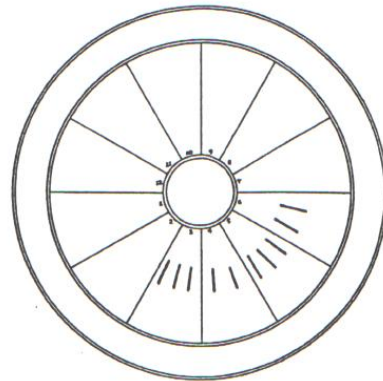

BOWL

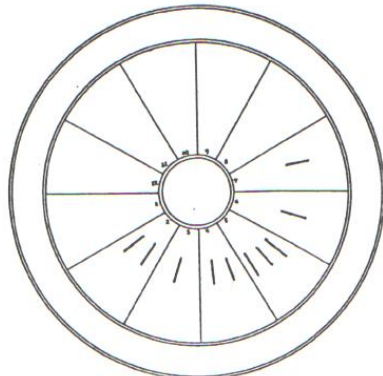

BUCKET

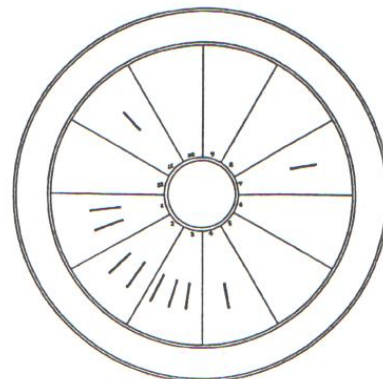

For Your Notes

Chart Patterns - Chart 1

The Splash Pattern

RECORDINGS 23-24

HENRY MANCINI
APRIL 16, 1924
00:10 A.M. EST
81 W 42
41 N 30

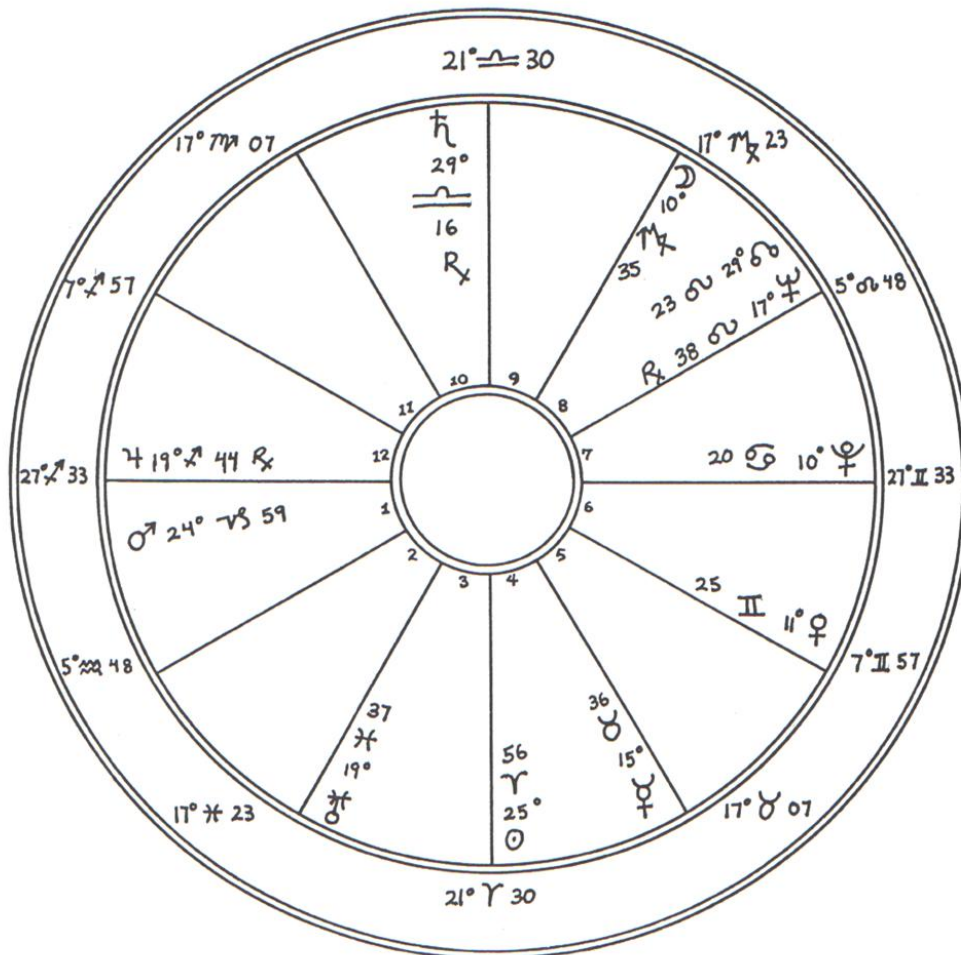

For Your Notes

Chart Patterns - Chart 2 The Locomotive Pattern

RECORDINGS 23-24

HENRY KISSINGER
MAY 27, 1923
5:30 AM
12 E 52
49 N 19

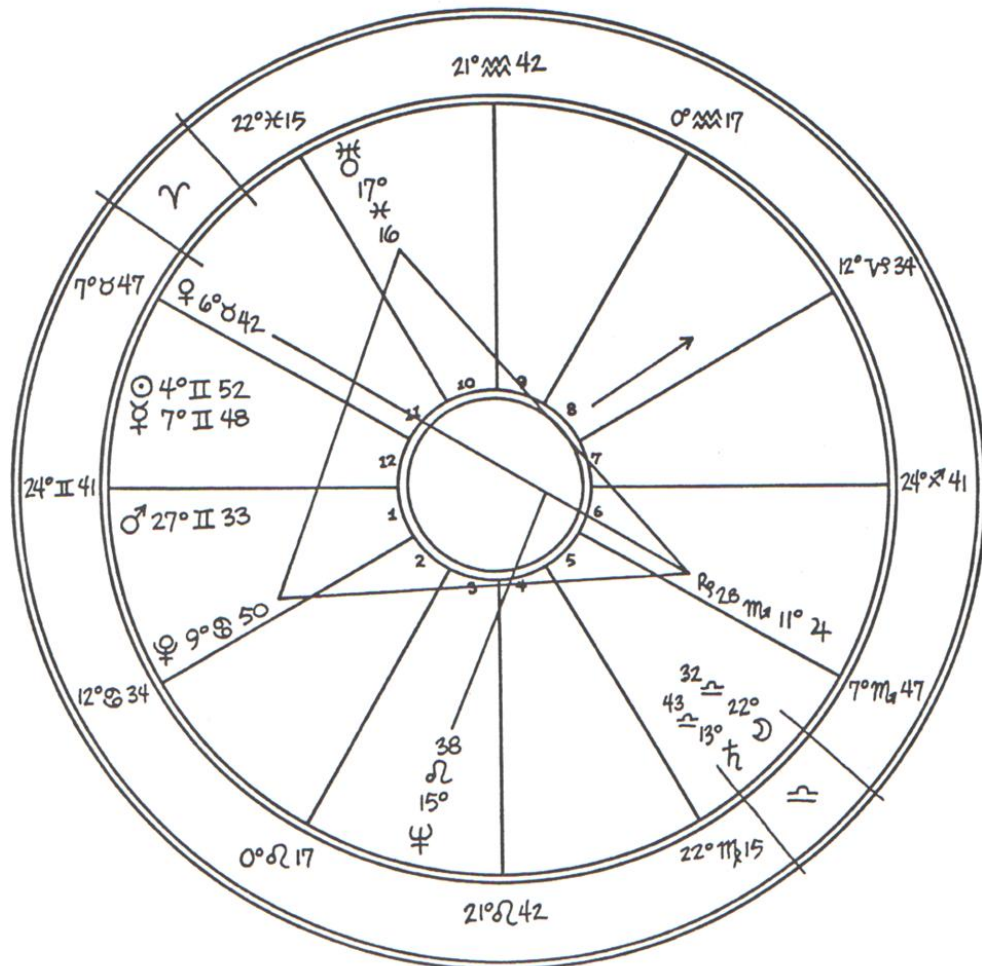

For Your Notes

Chart Patterns - Chart 3

The Bundle Pattern

RECORDINGS 23-24

BENITO MUSSOLINI
JULY 29, 1883
2:00 PM
DOVIA, ITALY

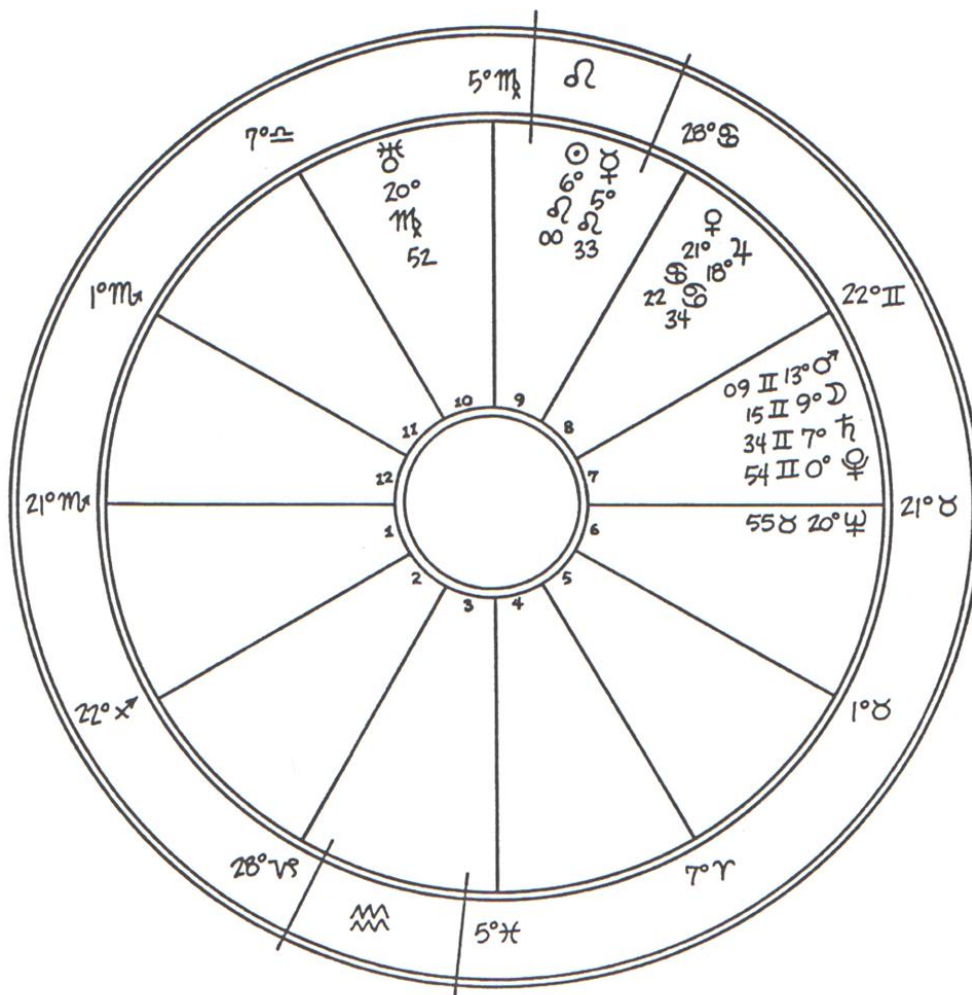

For Your Notes

Chart Patterns - Chart 4

The Bowl Pattern

RECORDINGS 23-24

BARBRA STREISAND
 APRIL 24, 1942
 5:16 AM EDT
 BROOKLYN, NEW YORK

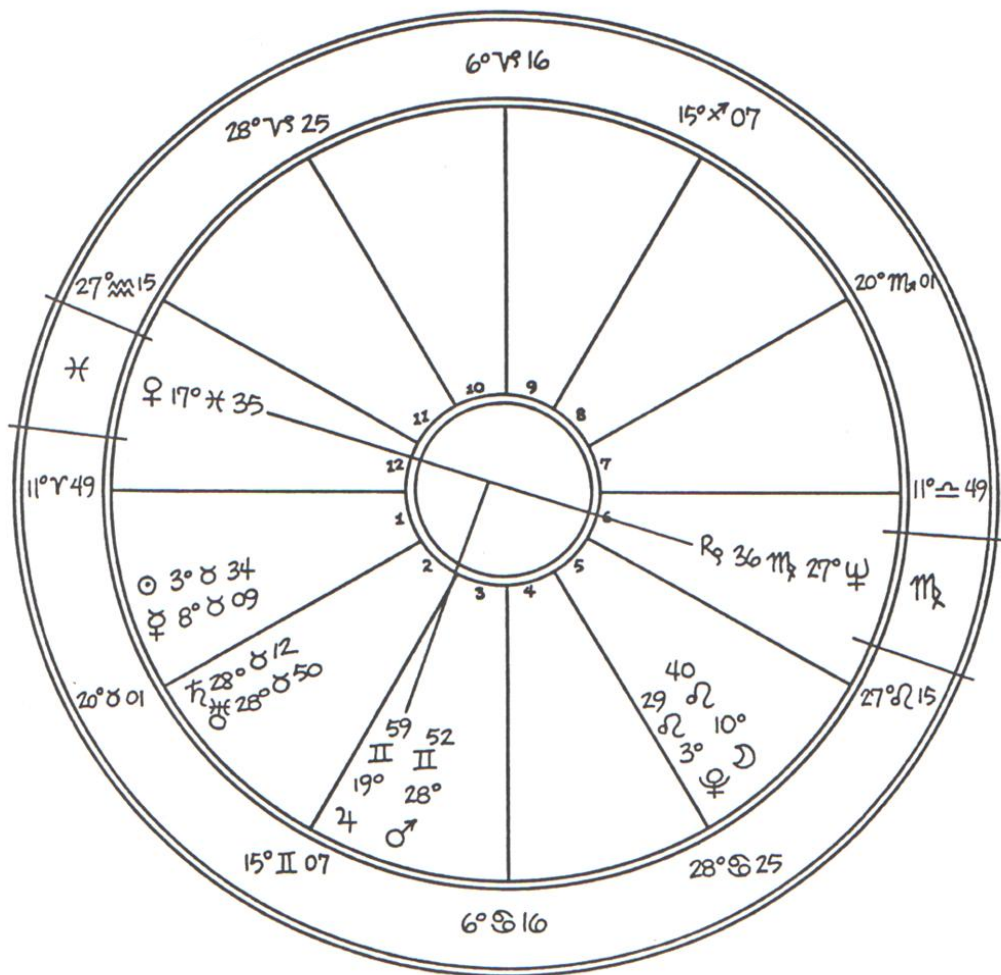

For Your Notes

Chart Patterns - Chart 5

The Bucket Pattern

RECORDINGS 23-24

CAROL BURNETT
APRIL 26, 1933
4:15 AM CST
SAN ANTONIO, TEXAS

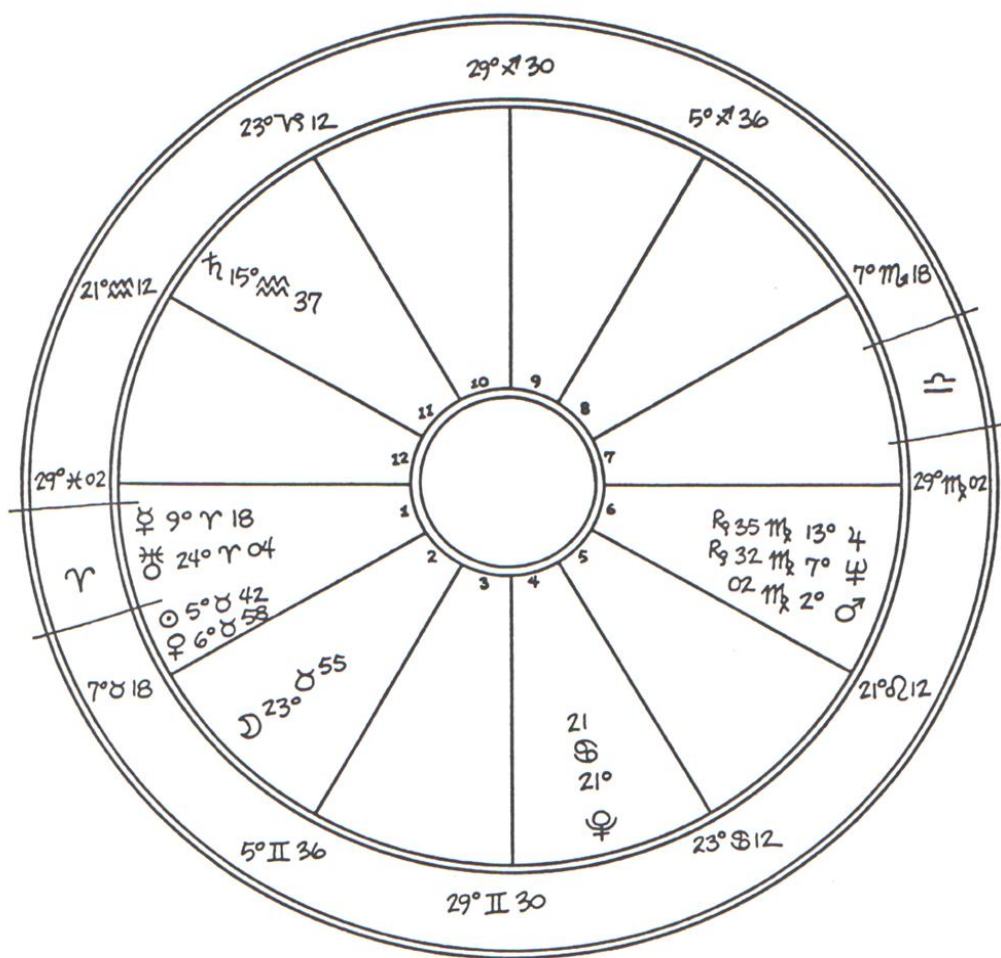

For Your Notes

Chart Patterns - Chart 6
The See-Saw Pattern
(The Hour Glass Pattern)

RECORDINGS 23-24

JIMMY CARTER
 OCTOBER 1, 1924
 6:00 AM CST
 PLAINS, GEORGIA

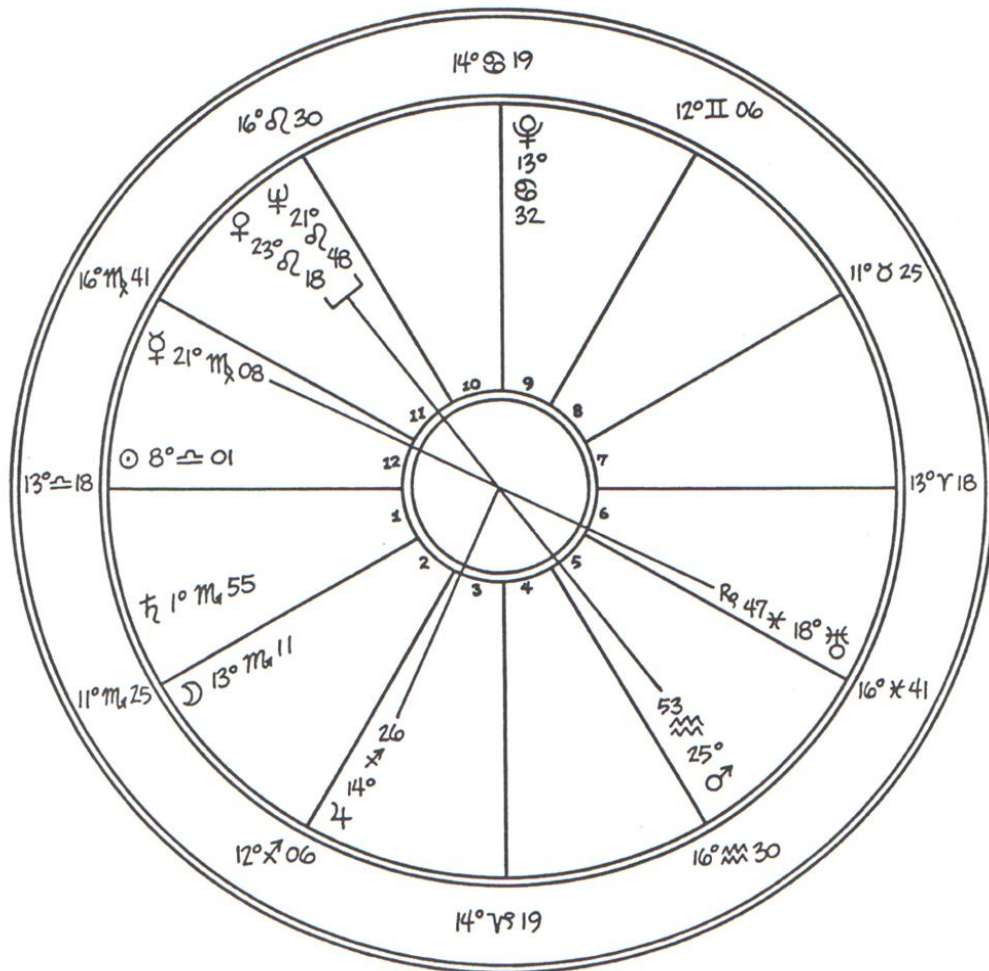

For Your Notes

Chart Patterns - Chart 7

The See-Saw Pattern

(The Hour Glass Pattern)

RECORDINGS 23-24

JOHNNY CASH
FEB. 26, 1932
8:09 AM CST
PINE BLUFF, ARKANSAS

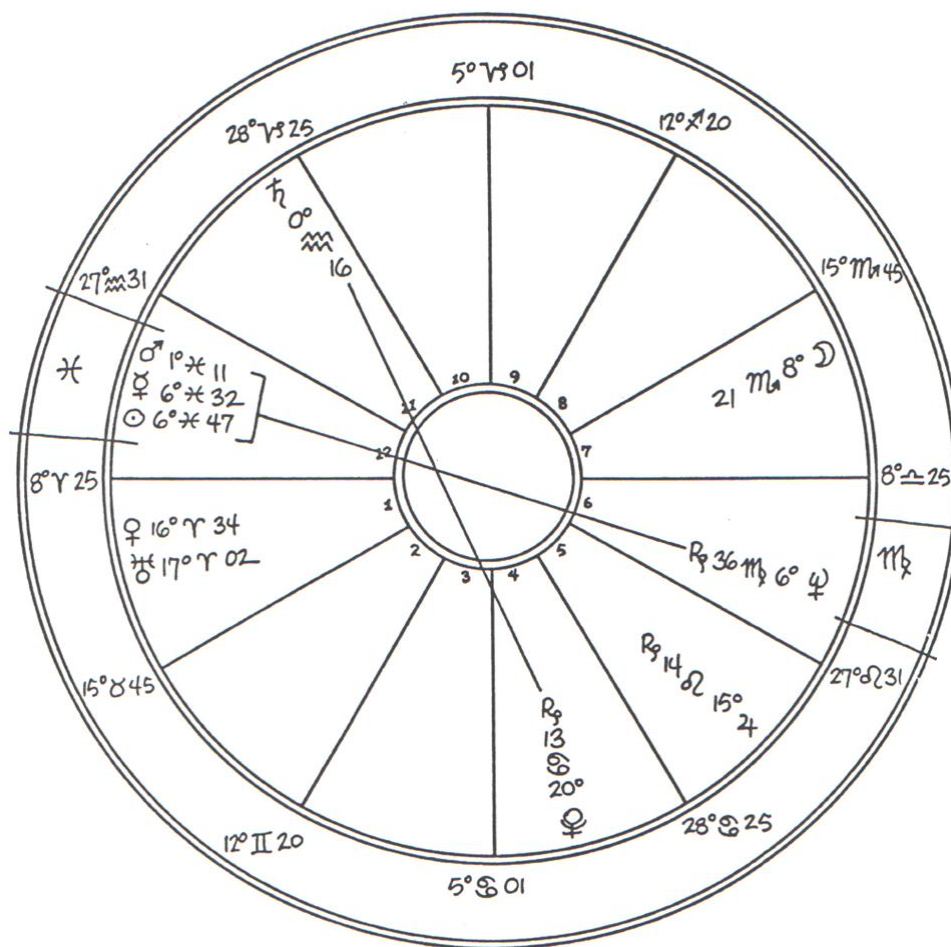

For Your Notes

RECORDING 25

Please read pages 261–269
in *The Wisdom and Way of Astrology*

For Your Notes

RECORDING 26

Please read pages 269–279
in *The Wisdom and Way of Astrology*

For Your Notes

RECORDING 27

Please read pages 279–291
in *The Wisdom and Way of Astrology*

For Your Notes

RECORDING 28

Please read pages 291–293 and 15–59
in *The Wisdom and Way of Astrology*

For Your Notes

This is a blank page.

For Your Notes

How to Become a Practicing Astrologer
Self-evaluation Test #10

1. A key characteristic of the fire element is

2. What astrological point does the birth longitude and local mean time give us in a horoscope?

3. How many houses are there in a horoscope?

4. What are the minimum and maximum degrees a house can contain?

For Your Notes

5. What two cusps indicate the horizon?

6. A key characteristic of the earth element is

7. What astrological point does the birth latitude give us in a horoscope?

8. Planets that are direct in motion work to externalize their energies. However, when a planet is retrograde in motion that planet works to _____ their energies.

9. What are the four most important cusps?

For Your Notes

10. What are these vital cusps called?

11. A key characteristic of the water element is

12. What two cusps indicate the meridian?

13. A key characteristic of the air element is

14. The planets signify what in a person's life?

15. The signs signify what in relation to the planets?

For Your Notes

16. The houses indicate what in a person's life

17. An aspect indicates what two things?



For Your Notes

11. Delineation of the Planetary Aspects

RECORDING 29

On the following pages you will find some brief statements for the key effects of the aspects. It is far from complete, but will give you a good foundation for how to interpret aspects.

- 1) Independent of the aspects that planets form, you should examine the type of signs they are in: cardinal, fixed or mutable. Planets in *cardinal* signs can very easily cause sudden, strong changes, mentally or physically. Aspects from cardinal signs are the strongest.

Planets in *fixed* signs act less severely than in the other two types of signs. Often the aspect tends to be more dormant for longer periods of time.

Planets in *mutable* signs show indecision and therefore vacillation. Most critically, the health is often affected and/or accidents may occur. In either case aspects from the mutable signs are often the most troublesome.

For Your Notes

- 2) The beginner should count the aspects from sign to sign; never from house to house! I repeat: aspects are never from house to house. They are always from sign to sign.

For example, all true squares exist in the same quality; however, because of the orbs of influence, the quality of the signs might be different, and therefore not as strong.

Because this is a beginner's book, we will example the aspects only as harmonious (trine, sextile, and positive conjunction), or inharmonious (opposition, square, and negative conjunction). This will allow you to get a good foothold on astrology. Remember, however, that the trine is stronger and more harmonious than the sextile; that the square is stronger and more inharmonious than the opposition. The conjunction is harmonious or inharmonious depending upon whether the planets are harmonious are not. With this in mind, let's look at the aspects in greater detail.

For Your Notes

☽ THE ASPECTS OF THE MOON ☽

Moon in aspect to Mercury:

Harmonious: Quick and accurate mind. The mind and emotions blend producing much creativity in mental pursuits; good communications with women.

Inharmonious: Quick and clever mind but often careless; tendency to gossip. Often poor communications with women or the general public.

Moon in Aspect to Venus:

Harmonious: Affectionate, gentle, harmonious personality; artistic talent.

Inharmonious: Complications and discord may occur in love and home environment.

Moon in aspect to the Sun:

Harmonious: The emotions and self-expression are in harmony. Produces good relations with the opposite sex. Has a good overall effect on the personality, endeavors, business and otherwise; harmonious home environment.

For Your Notes

Inharmonious: Has a wide effect which often produces discord in the home or business; the emotions and self-expression are often in conflict.

Moon in aspect to Mars:

Harmonious: Produces good health. The individual is quick, energetic, and robust. Positive relations with women.

Inharmonious: Produces an impulsive nature, often overly expressive of emotions, tends to fight a great deal, quick-tempered; there may be discord with women.

Moon in aspect to Jupiter:

Harmonious: Produces a personality that is kind and generous; popular with the general public.

Inharmonious: The person is often extravagant; this aspect often produces legal problems.

For Your Notes

Moon in aspect to Saturn:

Harmonious: Self-controlled and hardworking; thrifty and careful. Harmonious and long lasting relations with the mother, and/or women.

Inharmonious: Miserly person; often produces selfishness; the individual tends to be reclusive and does not blend well with the general public.

Moon in aspect to Uranus:

Harmonious: Often, unexpected positive events and benefits come into the person's life. Creative and unusual, magnetic personality.

Inharmonious: Can produce an eccentric personality; emotional and explosive temperament.

Moon in aspect to Neptune:

Harmonious: Triggers strong spiritual aspirations. The person is creative, imaginative, sensitive and intuitive.

Inharmonious: Person can tend to be irresponsible, critical, and fault-finding. Can easily be influenced by negative people.

For Your Notes

Moon in aspect to Pluto:

Harmonious: Intuitive abilities, self-regenerative qualities.

Inharmonious: Lacks consideration, negative psychic experiences, domestic upheavals; domination by women.

☿ THE ASPECTS OF MERCURY ☿

Mercury in aspect to Venus:

Harmonious: Refined and gentle personality with agreeable manners. The mind enjoys and is talented in the field of the arts or music.

Inharmonious: Problems in love, money, and mental attitudes.

Mercury in aspect to the Sun:

Harmonious: The only aspect is the conjunction, which is thought to produce a good, intelligent mind.

Inharmonious: None formed.

For Your Notes

Mercury in aspect to Mars:

Harmonious: The person likes to work with his mind; he likes to keep the mind continually active. It is quick and sharp. Produces an excellent debater.

Inharmonious: Good mind, but can tend to be caustic or sarcastic and careless; can be prone to accidents; or dishonesty.

Mercury in aspect to Jupiter:

Harmonious: An excellent speaker, teacher or lawyer; good sound judgment. Luck in mental pursuits. May travel a great deal and enjoy it very much.

Inharmonious: Exaggerates and can tend to be too optimistic. Tends to be careless in speech and regarding details.

Mercury in aspect to Saturn:

Harmonious: A good sound mind; the mind is practical, cautious, but thorough in making decisions. The person tends to be quiet.

Inharmonious: Brings a great deal of work into the person's life. A tendency to become solemn or depressed; negative outlook on life.

For Your Notes

Mercury in aspect to Uranus:

Harmonious: Produces a creative, brilliant, artistic individual. The mentality and speech is ingenious and clever. A unique and likeable individual.

Inharmonious: Produces genius but also may be eccentric in a disagreeable manner.

Mercury in aspect to Neptune:

Harmonious: Produces mystical attitudes. Delicate mind which enjoys harmony, art, music, or poetry.

Inharmonious: Produces a person who can be easily deceived and self-deceived. The speech may be vague, impractical, and misunderstood quite frequently.

Mercury in aspect to Pluto:

Harmonious: Clairvoyant, intellectually interested in many things. Motivated towards intellectual self-improvement.

Inharmonious: Sarcasm, suspicious, fanatical views, prying curiosity.

For Your Notes

♀ THE ASPECTS OF VENUS ♀

Venus in aspect to the Sun:

The conjunction is the only *major* aspect formed between Venus and the Sun.

The conjunction of the self-expression of the Sun and the affections of Venus is harmonious. It produces a likable person, who is artistic. People who have this aspect are not rapidly judged by others even when they do negative things. This conjunction can cause the person to become too self-centered. See glossary: Combust and Cazimi.

Venus in aspect to Mars:

Harmonious: A very demonstrative person in the affections. There is a fondness for pleasure and enjoyment; a positive attraction between the opposite sex.

Inharmonious: Often produces negative emotionality in sexuality. Quarreling in the love life. Difficulty handling money; there can easily be losses in money matters.

For Your Notes

Venus in aspect to Jupiter:

Harmonious: A generous, sociable individual; very affectionate and demonstrative. There will be a love of sports, studying, or pursuing higher educational goals; there may be over-indulgence.

Inharmonious: Careless and self-indulgent. There may be over-indulgence in love, sex, food, and liquor. May have difficulty holding on to money.

Venus in aspect to Saturn:

Harmonious: This aspect steadies and stabilizes matters of finance, money, love and affection. Good fortune in money through older people. Good investments are in buildings and land.

Inharmonious: Affections are directed toward few persons, older persons. There is a tendency to be exacting and selfish.

Venus in aspect to Uranus:

Harmonious: Attractive personality with artistic and romantic tendencies. The person may acquire money in unusual ways. Love life may be unusual but satisfactory.

For Your Notes

Inharmonious: Person will tend to be unfortunate romantically; there can be explosive love relationships. Can produce a person who is jealous and very attached.

Venus in aspect to Neptune:

Harmonious: The personality is genteel, romantic, poetic, artistic, or musical. Often produces a love for the mystical or spiritual.

Inharmonious: The high ideals of this aspect may not be attainable, causing disillusionment and disappointment. Tendency toward deception in love and money matters.

Venus in aspect to Pluto:

Harmonious: Creative endeavors, inspirational. Love relationships regenerate.

Inharmonious: Selfishness, strong sex drive, no social refinement. No thought of other's needs; jealousy.

For Your Notes

☉ THE ASPECTS OF THE SUN ☉

Sun in aspect to Mars:

Harmonious: Produces a personality that is energetic and courageous; the person finds success in any undertaking because of this; can accomplish most anything he sets his mind to.

Inharmonious: The same as the harmonious aspect but too self-willed and emotional. Can produce a violent personality; energy is often dissipated.

Sun in aspect to Jupiter:

Harmonious: The person is sincere, generous and fond of religion, philosophy, and/or sports. Can be successful in the professions: a doctor, lawyer, professor.

Inharmonious: The person will be unlucky in gambling and law; he is often too venturesome. Conflict between philosophical opinions, the self, and superiors.

Sun in aspect to Saturn:

Harmonious: Patient and hardworking individual; good relationship with authoritarian figures; success through persistency.

For Your Notes

Inharmonious: Finds difficulty with organizations and authoritarian figures. Finds delays in accomplishing feats and in most ventures.

Sun in aspect to Uranus:

Harmonious: Person is energetic and has a powerful mind. A born leader; a symbol of charisma. Broad-minded individual.

Inharmonious: Same as the harmonious but too self-willed and stubborn. Often tactless with offensive personality quirks; high strung.

Sun in aspect to Neptune:

Harmonious: Produces an inclination toward the mystical life; or toward music and art. Good imagination. Tendency to be secretive.

Inharmonious: Susceptible to negative influences; prone to being dependent on alcohol, drugs, etc. Leans toward self-deception.

For Your Notes

Sun in aspect to Pluto:

Harmonious: Positive will power, dynamic self-expression.
Constructive leadership, and inner unfoldment.

Inharmonious: Self-assertive, strong sexual stimulus; unsympathetic,
negative transformations, attempts to dominate and coerce people.

For Your Notes

♂ THE ASPECTS OF MARS ♂

RECORDING 30

Mars in aspect to Jupiter:

Harmonious: Enterprising, generous, and enthusiastic individual. Success often through medicine, law, or religion; a person who has drive and skill to accomplish his goals.

Inharmonious: Person is extravagant and can tend to gamble or be careless with money and valuables.

Mars in aspect to Saturn:

Harmonious: A practical, worldly individual who is often a little severe, but able to accomplish his pursuits through a steady driving energy force. A very responsible individual.

Inharmonious: Irresponsible individual; person may overwork toward his goals. Hardworking individual, but too much so, unable to extend himself in love matters; can have cruel tendencies.

For Your Notes

Mars in aspect to Uranus:

Harmonious: A power personality; often domineering, however, with great physical and emotional energies. Success in electronics, astrology, aviation and Uranus professions.

Inharmonious: Difficulty in controlling the temper; high strung and overly energetic. Needs to watch out for unexpected misfortunes.

Mars in aspect to Neptune:

Harmonious: Produces deep feelings and strong emotions which one is able to express positively. One is highly active and involved with art, music, or spiritual endeavors.

Inharmonious: Person may be deceitful to others; the imagination can be destructive. Can produce obsessions, fears, and vices.

Mars in aspect to Pluto:

Harmonious: Intensified energy, constructive impetus to accomplish; adventurous.

Inharmonious: Aggressive, autocratic, coercing nature, conflicts, sexual jealousy. Anger and conflict. Strong accident proneness.

For Your Notes

∩ THE ASPECTS OF JUPITER ∩

Jupiter in aspect to Saturn:

Harmonious: A thoughtful and stable person having much common sense; having a good, stable, philosophical outlook toward life. Gains through older persons or governments.

Inharmonious: Lack of positive enterprise. Can produce narrow religious or philosophical views.

Jupiter in aspect to Uranus:

Harmonious: Originality and creative genius in the realm of religion, law, or medicine.

Inharmonious: Tendency toward revolutionary tendencies on a small or large scale toward religion or governments.

Jupiter in aspect to Neptune:

Harmonious: A person who is sympathetic and humane toward charitable or needy causes or institutions. Activates the mystical; a concern over the mass of mankind.

For Your Notes

Inharmonious: Vagueness in one's religious beliefs or philosophy. An emotional individual; self-deception can occur.

Jupiter in aspect to Pluto:

Harmonious: Benefits from religion, law, and education. Interest in self-improvement. Liking for studying.

Inharmonious: Deception with money. Danger from occult, psychism. Extreme ideas of religion and law.

♄ THE ASPECTS OF SATURN ♄**Saturn in aspect to Uranus:**

Harmonious: Good blending of persistency and will; blending of common sense and originality.

Inharmonious: Limited originality; stubbornness; tending to follow wrong path.

For Your Notes

Saturn in aspect to Neptune:

Harmonious: Concrete, practical ideas and ideals. Common sense; the quality to organize.

Inharmonious: Cynicism, coldness of spirit; Difficulty in spiritual development.

Saturn in aspect to Pluto:

Harmonious: Increased concentration and will power. Disciplined, insightful. Advancement in life.

Inharmonious: Tends towards coerciveness and enforced conformity to his will; often has deep secrets regarding job.

♃ THE ASPECTS OF URANUS ♃

Uranus in aspect to Neptune:

Harmonious: Interest in art, psychic and metaphysical topics.

Inharmonious: Difficulty with psychics, occult matters, and painting.
Likes strong, strange art.

For Your Notes

Uranus in aspect to Pluto:

Harmonious: Mystical experiences, resourceful; corporate benefits; self-reliance.

Inharmonious: Often drastic life changes; disruptive experience; revolutionary sentiments. Financial loss.

Ψ THE ASPECTS OF NEPTUNE Ψ**Neptune in aspect to Pluto:**

Harmonious: Interest in art and metaphysics; insights and exploration of life.

Inharmonious: Psychic and/or dream problems; eruption of subconscious forces. Difficulties with drugs, alcohol, and so forth. Often, spiritual problems.

The aspects of Pluto have been covered by the faster moving planets. In short, because Pluto is the slowest moving planet, it forms no aspects with other natal planets. The other natal planets form aspects with *Pluto*.

For Your Notes

You have now completed your study of the four main areas of astrological study: P.H.S.A. You should now go back over each area and master the key words and symbols. This will make further progress much easier. It will, also, allow you to start reading charts for people right away. This is truly the only way to really learn astrology!



For Your Notes

Study Guide

DATA TO STUDY FROM DELINEATION OF THE PLANETARY ASPECTS

RECORDINGS 29 AND 30

- A) Reread this chapter and underline key words ... get a feeling for the aspects.
- B) Reread the underlined words and obtain a better feeling for the aspects.
- C) Use your set of aspect flash cards to look at a few times a day. Remember: if you learn the meaning of the planets and the meaning of the aspects, each will become clear as you look at them. Try to see how the key words for each planetary aspect were formed.



For Your Notes

12. Delineation of Planetary Strengths

RECORDING 31

This section can be set aside for later study. If you wish you can read through this chapter to get a general idea of planetary strengths and return to it at a later date.

It's obvious that the luminaries and the planets exist in everybody's horoscope, but are not equally felt. This is because certain planets are stronger and others are weaker in different signs and houses. As we learned in the chapter on the planets, the psychological urges or drives are modified by the zodiacal sign they are in.

It is important that you are able to determine the strength or weakness of a planet. These are determined by five forces:

- 1) **Sign position:** Each planet in each zodiacal sign is strong or weak depending upon the harmony or disharmony of the planet to that zodiacal sign. A planet vibrates the most positive and the strongest when it is located in its own sign, i.e., in the sign that it

For Your Notes

rules. For example, Jupiter is far stronger and more positive in Sagittarius, than when it is in Gemini (the opposite sign of Sagittarius). Venus is stronger and more positive in Taurus, than when found in Scorpio (the opposite sign of Taurus).

- 2) **House position:** The second factor to look at is the house position of a planet:

Angular houses: If a planet is in an angular house (1st, 4th, 7th, 10th), it is considered strong. Its strength approximates that of being in its own sign.

Succedent houses: If a planet is in a succedent house (2nd, 5th, 8th, 11th), it is much weaker than when in an angular sign.

Cadent houses: If a planet is in a cadent house (3rd, 6th, 9th, 12th), it is very weak, and the negative qualities of the planet tend to manifest more easily.

- 3) **Aspects to the planets:** Independent of the strength of a planet, the positivity or negativity of its influence is clearly indicated by its aspects. The closer the aspects, the stronger the force—for better or worse. The greater the number of aspects to a given

For Your Notes

planet, the stronger that planet will be (harmoniously or inharmoniously).

- 4) **Conjunct cusps:** Planets that are conjunct the house cusp are quite strong.

- 5) **Conjunct the angles:** Planets conjunct the angles (1st, 4th, 7th, and 10th) are very, very strong. Planets approaching the angles are much stronger than planets that have already touched that angle.



For Your Notes

Reading an Ephemeris
Calculating a Flat Chart

RECORDING 31

This recording deals with how to read an ephemeris. Please refer to and use a Noon Ephemeris for 1985.

A *flat chart* is a chart drawn up for a person when you don't know where or what time the person was born. The 1st house cusp is always 0 degrees Aries, the 2nd house cusp is always 0 degrees Taurus, etc.

Using this 1985 ephemeris, the assignment that Kriyananda gives you at the beginning of the recording is to draw up a flat chart for March 7, 1985. This is discussed on the recording.

He then requests that in order to familiarize yourself with drawing up flat charts and horoscopes in general, draw four of your own zodiacal wheels, sectioning them with 12 houses, and then draw up flat charts for the following dates:

March 1, 1985

March 10, 1985

For Your Notes

March 20, 1985

March 30, 1985

We have included four blank charts in your course materials if you choose to use more formalized wheels.



For Your Notes

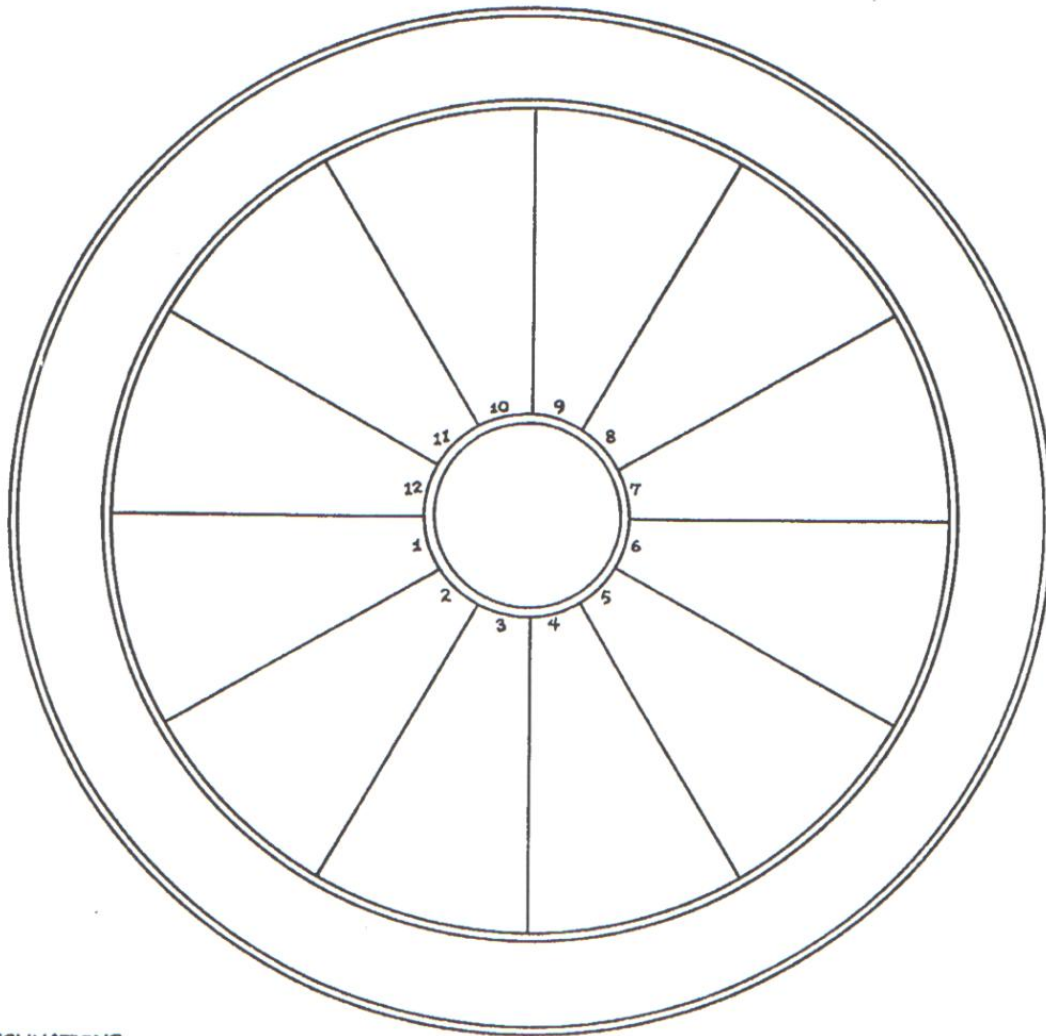

DECLINATIONS

	☉	☉																			
	☽		☽																		
	♃			♃																	
	♄				♄																
	♅					♅															
	♆						♆														
	♇							♇													
	♈								♈												
	♉									♉											
	♊										♊										
	♋											♋									
	♌												♌								
	♍													♍							
	asc														asc						
	MC															MC					
	♎																				♎

CARDINAL	
FIXED	
MUTABLE	
FIRE	
EARTH	
AIR	
WATER	

Temple of Kriya Yoga
 2414 N. Kedzie Blvd.
 Chicago, IL 60647
 (773) 342-4600

For Your Notes

13. A Blending of P.I.H.A.

RECORDING 32

When interpreting the *planet's* urge, look to the zodiacal *sign* which will show how that urge is modified. Then look to what house the planet is in, in order to see *where* that urge will manifest. Then look and see if the planet forms any aspects.

Here is the secret of reading a chart: You look to the house area. Then find the sign on the cusp of that house. The ruler of that sign is the symbolical indicator of that area.

For example, if you are interested in a person's finances, you look to the 2nd house. Then you see what sign is on the 2nd house cusp. If it is Virgo, then that symbol is the symbol of that person's money.

Deeper insights can be gained by examining the ruler of Virgo, which is Mercury. By examining Mercury by sign, house and aspects, you find a wealth of information regarding that person's finances.

For Your Notes

If Scorpio were on the 2nd house cusp, then this sign is the key symbol of a person's wealth. Pluto being the ruler of Scorpio, if examined by sign, house and aspect will give deeper insights into that person's finances.

If Capricorn were on the 2nd house cusp, then Capricorn would be the symbol of that person's money matters. Saturn, the ruler of Capricorn, by sign, by house and by aspect will tell you more about that person's finances.

Remember: In reading a planet, the first thing is to see what sign that planet is in, and how that sign modifies the planetary urge. For example, the Sun is the planet of self-expression. Placed in Virgo, the self-expression would tend to be more introverted, critical, and analytical. That personality is drawn to details, the qualities of Virgo.

Similarly, Mars, the planet of action, would be much more forceful, assertive, and outgoing in the sign Aries, than in the sign Cancer, where it would be more sensitive and fearful.

Mars, the urge to struggle, in the 4th house would show difficulties in the home environment. Whereas, Mars in the 5th house would show a tendency for struggles and fights with lovers, children, and/or over creativity.

For Your Notes

Jupiter in the 7th house would show expansion of good fortune with partnerships, in either marriage or business. Whereas, Jupiter in the 2nd house would show good fortune in money matters.

Having explored the meanings of PSHA, it is essential that you now gain a clearer understanding of the four areas. This is done best by memorizing key words and symbols. After that, it's just a matter of reading them, reading them and reading them until you find that they will flow easily and joyfully from your mind. It's just like learning a simple language: You have to speak it.

After you gain a better understanding of the planetary urges, the modification by the signs, the house areas, and the meaning of the aspects, delineation is then only a matter of looking into a horoscope and blending this knowledge to gain insight into a person's personality and life-patterns.

Before going on, here is a review of some basic suggested steps in delineating a horoscope derived from what you have learned. Look at the planets and delineate their effects by asking:

- 1) What is the planet's urge?

For Your Notes

- 2) What attributes are given to that planet by the sign?
- 3) Is the planet harmonious or inharmonious; strong or weak in that zodiacal sign?
- 4) In what area of the person's life will the planet manifest?
- 5) Is the planet in an angular house, or near a cusp?
- 6) Are the aspects harmonious or inharmonious; strong or weak?

Then make a list of the aspects. Start with the fastest moving planet (Moon) and see with which planets the Moon forms aspects. Then go to the next fastest moving planet (Mercury), and see with which planets Mercury forms aspects with, all except the Moon because you have already listed it. Then move to the next fastest moving planet (Venus) and see with which planets it forms aspects, with the exception of the Moon and Mercury. Then continue with the rest of the planets. Behind each aspect mark whether it is harmonious or inharmonious; weak or strong. Thus at a glance you can see the nature of the person's life. With this basic knowledge you can gain extensive insight into any person's life.

For Your Notes

In this chapter, I have included a delineation of a few planets found in the following horoscope:

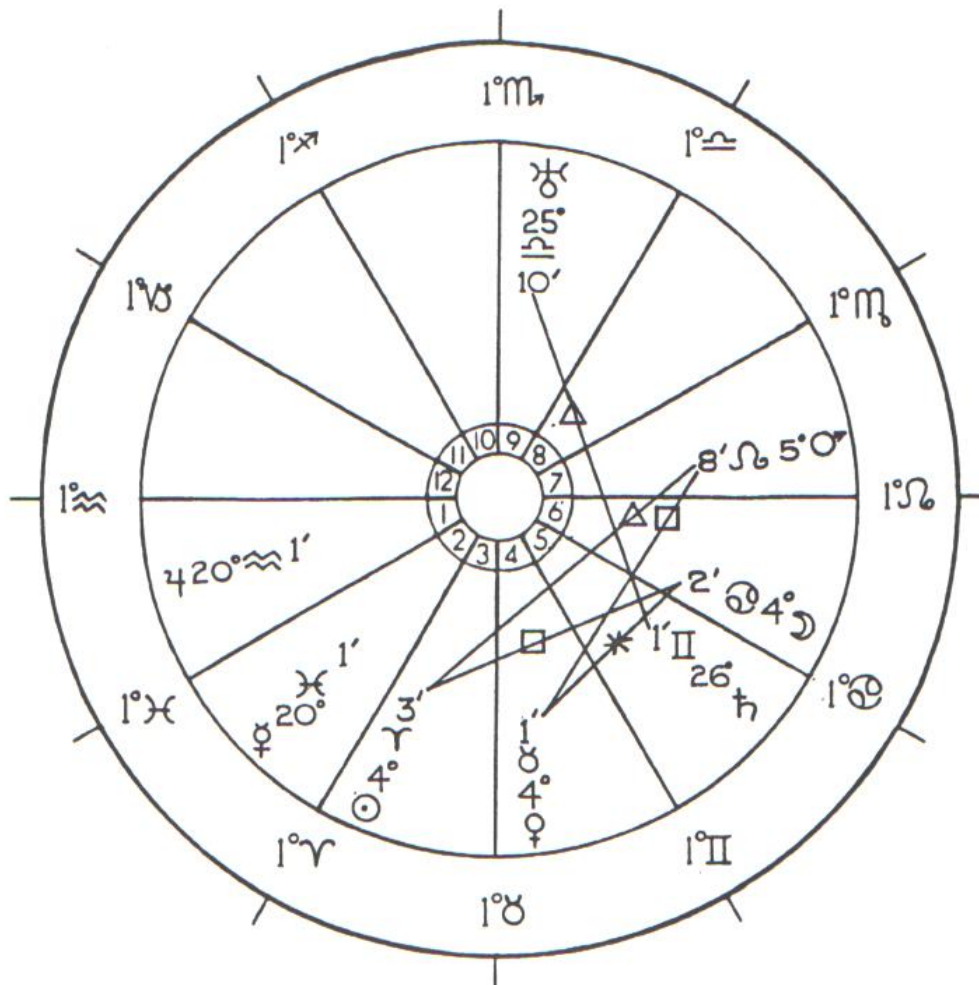

1. The Sun is in Aries. The Sun being the single most important planet in the chart, the symbol or urge for life and vitality, the individual himself, it is examined first. The Sun in Aries symbolizes an individual who is bold,

For Your Notes

- assertive and energetic, perhaps a little impatient, but enthusiastic.
2. The Sun, exalted in Aries, makes this planetary position quite strong. The fiery Sun blends well with the vibration of fiery Aries allowing it to manifest well. Thus the self-expression of the individual, represented by the Sun, will tend to be harmonious and strong.
 3. The Sun is in the 3rd house, a cadent or weak house. This will tend to temper the fiery Aries nature. Much of the self-expression of the individual will be through talking, rather than through doing.
 4. The Sun is located in the 3rd house of communication, thus the solar urge will be most comfortable in the field of communications; perchance in the field of teaching, lecturing or writing. This individual will 'shine best' as an educator or communicator, because where the Sun is you shine best.
 5. The Moon rules the emotions, and is in the sign of Cancer, another emotional sign. Thus the emotions will tend to be sensitive, and very changeable. It will manifest

For Your Notes

a strong emotional nature, hard to understand because the root cause of the emotions will be hidden. However, the Moon rules Cancer, causing many positive traits to manifest. The feelings will be expressed in a sensitive, direct manner. Yet, often the expressions will be overly sensitive. This is a standard Cancerian manner. This positive position of the Moon would soften other inharmonious influences of the Moon.

6. The Moon in Cancer will cause women to be predominant and important in the person's life. Whether these women are pleasant or unpleasant will depend upon the aspects of the Moon.

7. The fiery Aries Sun is in square aspect to the Cancer Moon. Though the Sun and Moon are in positive signs, there will tend to be a strong disruptive force between the person's self-expression of the Sun, and the emotions of the Moon. The Aries Sun wants to be bold and daring, but the Cancer Moon wants to be domesticated and sensitive. Thus, there is a battle within the individual. This tends to produce a certain amount of underlying trouble with women (including mother) and health,

For Your Notes

because the Moon indicates health problems: weak vitality and/or stomach problems.

8. The Sun and Moon are in squared aspect and this, along with the fieriness of the Aries element will produce a person who will strive to accomplish things. This striving, or underlying tension in the person's life, will not be as apparent to the general public, as the Sun is in a cadent house. Were it in an angular house, it would be more noticeable to everyone.
9. Mercury is located in Gemini, the sign of its rulership. As Gemini is mental and inquiring, this person's mind will be intellectual and inquiring. The mind will be sound with good judgment because it's aspected to Jupiter. This will cause the person to have an interest in religion, law, and foreign cultures.
10. Mercury being in the 5th house, causes this person to be happy occupying himself with pursuits of creativity or pleasures. The person may find pleasure in teaching children. As the 5th house indicates children, and Mercury is having a positive strong aspect (trine to Jupiter), his children, more than likely will be well

For Your Notes

educated, and travel to foreign countries. Children will bring this person great happiness.

11. Mars is in Leo, in the 7th house. This tends to bring a great deal of energy and activity into marriage or partnerships. There will be strife due to the restless nature of the Mars. However it will have a harmonious outcome because it is trined to the Sun, which is the symbol of marriage and/or partnership. The position of Mars here will bring a very active and challenging spouse into the marriage.
12. Jupiter is in Libra, in the 9th house. This means success and happiness (Jupiter) will be found in a foreign country or far from the place of birth.
13. The ascending sign is Aquarius. Remember, the Ascendant rules the 1st house of one's worldly outlook, and often how the world sees the individual. In this case, the person would be viewed as a humanitarian, but more so viewed by the world as somewhat eccentric in nature (an attribute of Uranus, the ruler of Aquarius). The person will definitely value his own freedom (whether or not he values other's freedom).

For Your Notes

14. Neptune rules the 2nd house of money. Neptune is in Capricorn and in the 12th house, squared the Sun. This indicates that the person will have money problems due to hazy, nebulous thinking, perchance also from gambling.

These are just a few things that can be said about the delineation of this chart. When you begin to read a chart, merely take the key planets of the nativity and interpret them to the best of your ability by sign, house and aspect. The key planets are those in angular houses, those on cusps, and those planets with strong aspects to them.

Here, again, is the secret of reading a chart.

- 1) You look to a house area.
- 2) Then find the sign on the cusp of that house.
- 3) Then find the ruler of that sign. It symbolizes that area by:
 - a) sign position
 - b) house position
 - c) aspects

For Your Notes

In time, you will become more comfortable and skilled in doing this. As you can see, the study and interpretation of a chart is not that long, revealing wondrous things about your life, or other people's. Yes, it is a science and certainly not guesswork. However, like all things, there is an art to it. The major key in learning astrology is to read charts. Read ... read ... read. It's fun! It's fascinating. It's necessary.



For Your Notes

Chart Interpretation

RECORDING 32 CHART FOR INTERPRETATION

MALE
FEBRUARY 22, 1932
3:58 AM
DORCHESTER, MASS.

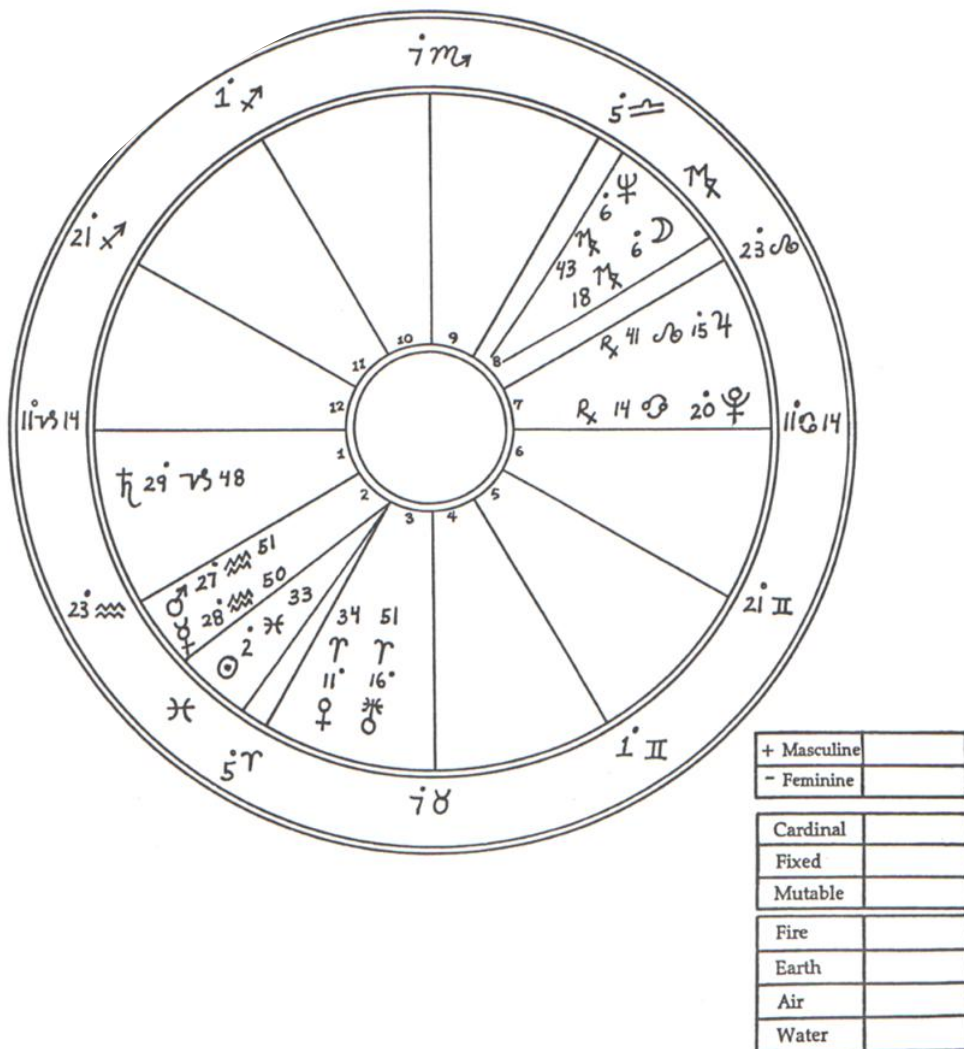

For Your Notes

RECORDING 33

Please read pages 356–364
in *The Wisdom and Way of Astrology*

For Your Notes

RECORDING 33

Using the February, 1954 ephemeris below, the assignment that Kriyananda gives you at the beginning of the recording is to draw up a flat chart for a person born February 20, 1954. He then discusses this chart with you. A blank horoscope wheel is included in this section for you to use.

Ephemeris, February 1954

SIMPLIFIED SCIENTIFIC
EPHEMERIS OF THE PLANETS' PLACES
Calculated for Mean Noon at Greenwich
February, 1954
New Moon, February 3, 3:54 P.M. in ♋ 14° 18'
Longitude of the Planets

Day	☉	☿	♃	♄	♅	♁	♂	♆	♁	♃	♄	♅
	♋	♋	♋	♋	♋	♋	♋	♋	♋	♋	♋	♋
M 1	12 06 11	12 43 24	30 14 11	9 08 16R33	25 19 20R11	25R59	23 05					
T 2	13 07 05	13 58 26	13 27 54	9 11 16 32	25 53 20 09	25 59	23 02					
W 3	14 07 58	15 14 27	55 11 58	9 13 16 31	26 27 20 07	25 59	22 59					
T 4	15 08 50	16 29 29	35 26 20	9 15 16 29	27 01 20 04	25 58	22 55					
F 5	16 09 40	17 45 1	14 10 55	9 16 16 27	27 35 20 02	25 58	22 52					
S 6	17 10 30	19 00 2	51 25 35	9 16 16 26	28 09 20 00	25 58	22 49					
S 7	18 11 18	20 16 4	26 10 13	9 17 16 26	28 43 19 58	25 58	22 46					
M 8	19 12 04	21 31 5	57 24 44	9 17 16 25	29 17 19 56	25 58	22 43					
T 9	20 12 49	22 52 7	24 9 03	9 18 16 25	29 50 19 54	25 58	22 40					
W 10	21 13 32	24 02 8	47 23 07	9 18 16 25	0 24 19 52	25 57	22 36					
T 11	22 14 14	25 18 10	05 6 56	9 19 16 25	0 57 19 50	25 57	22 33					
F 12	23 14 53	26 33 11	17 20 28	9 19 16 26	1 31 19 48	25 57	22 30					
S 13	24 15 31	27 48 12	23 3 46	9 19 16 26	2 04 19 46	25 57	22 26					
S 14	25 16 07	29 04 13	22 16 50	9 20 16 27	2 37 19 44	25 56	22 23					
M 15	26 16 42	0 19 14	12 29 41	9 20 16 28	3 10 19 42	25 56	22 20					
T 16	27 17 16	1 35 14	54 12 21	9 20 16 29	3 43 19 40	25 55	22 17					
W 17	28 17 48	2 50 15	26 24 51	9 20 16 30	4 15 19 38	25 55	22 15					
T 18	29 18 19	4 05 15	49 7 10	9 20 16 32	4 48 19 36	25 54	22 12					
F 19	30 18 47	5 20 16	03 19 20	9 20 16 34	5 20 19 34	25 54	22 08					
S 20	1 19 19	6 35 16	06 1 23	9 19 16 36	5 53 19 32	25 53	22 05					
S 21	2 19 40	7 50 15	59 13 19	9 19 16 38	6 25 19 31	25 53	22 02					
M 22	3 20 04	9 05 15	42 25 12	9 18 16 41	6 57 19 29	25 52	21 58					
T 23	4 20 27	10 19 15	16 7 04	9 18 16 44	7 29 19 27	25 51	21 55					
W 24	5 20 49	11 34 14	41 18 58	9 17 16 46	8 01 19 26	25 50	21 52					
T 25	6 21 09	12 49 13	57 1 01	9 17 16 49	8 33 19 24	25 49	21 48					
F 26	7 21 28	14 04 13	07 13 15	9 16 16 52	9 05 19 23	25 49	21 45					
S 27	8 21 45	15 19 12	12 25 46	9 16 16 55	9 37 19 21	25 48	21 42					
S 28	9 22 01	16 34 11	12 8 39	9 15 16 59	10 08 19 20	25 47	21 39					

Pluto, Longitude, February 1, 1954, ♄ 24° 06'R

For Your Notes

Chart Interpretation
RECORDING 33
FLAT CHART FOR INTERPRETATION

FLAT CHART
FEMALE
February 20, 1954

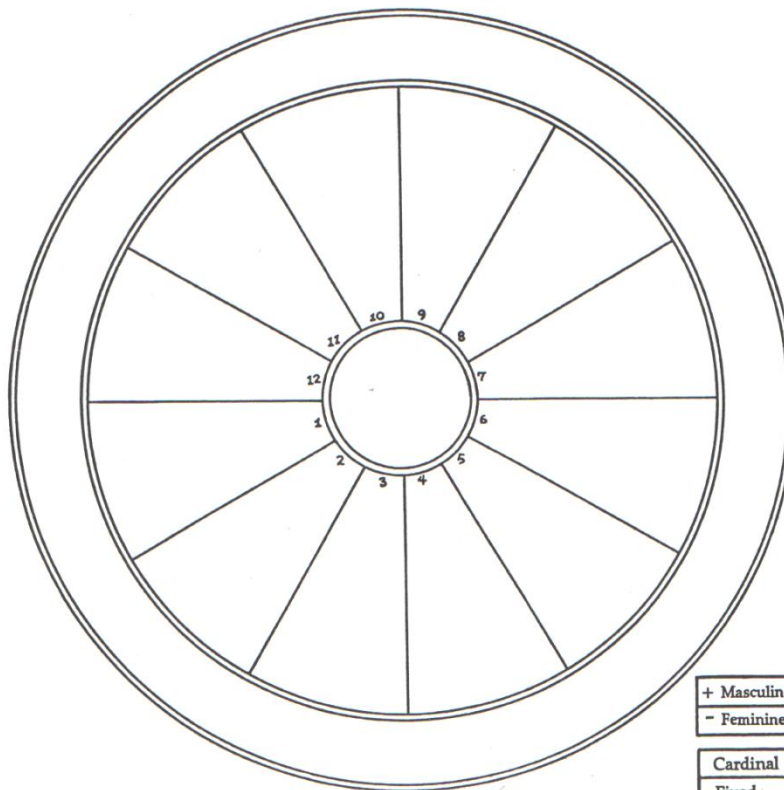

+ Masculine	
- Feminine	
Cardinal	
Fixed	
Mutable	
Fire	
Earth	
Air	
Water	

For Your Notes

RECORDINGS 34, 35, 36

Please read pages 365-367
in *The Wisdom and Way of Astrology*

For Your Notes

Chart for Interpretation

RECORDINGS 34, 35, 36
 CHART FOR INTERPRETATION

FEMALE
 JUNE 1, 1926
 9:30 A.M. PST
 LOS ANGELES, CA

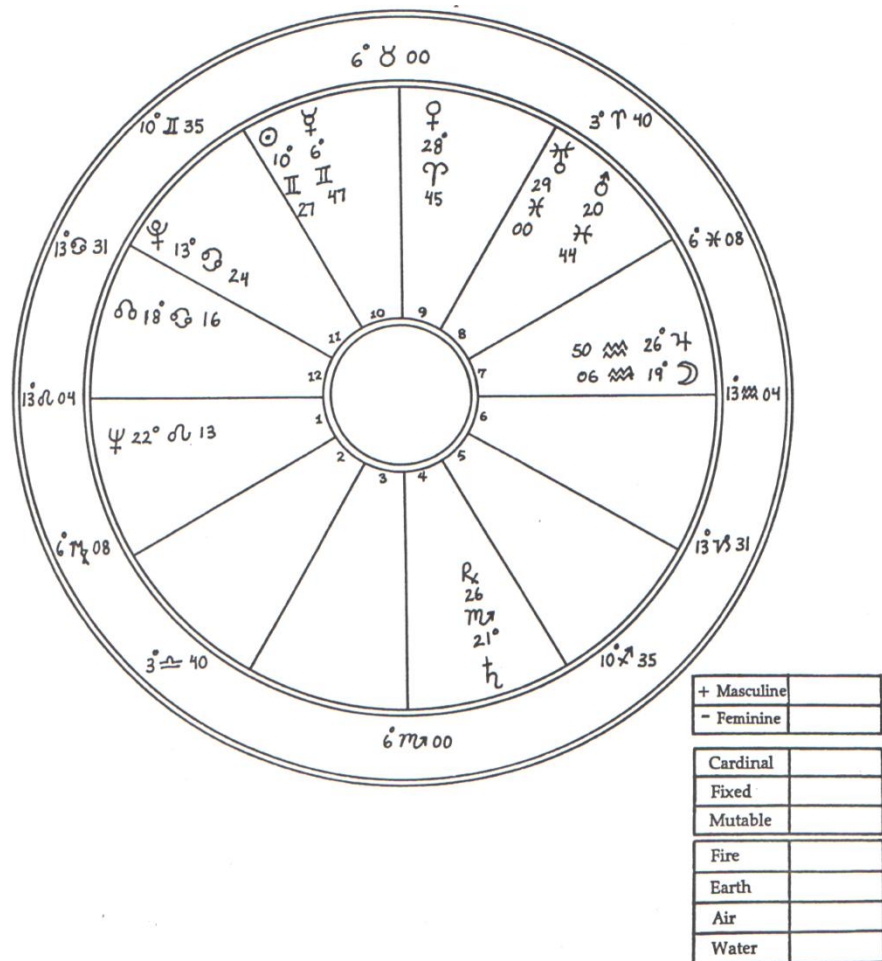

For Your Notes

RECORDING 35

You will notice that some of the chart examples have been repeated. This is to help you in your learning process. As Kriyananda mentioned earlier, repetition is the basis of learning. Since delineation is the key to understanding the natal chart, he has occasionally chosen to expand on the interpretation of one chart through more than one lesson.

For Your Notes

RECORDING 36

You will notice that some of the chart examples have been repeated. This is to help you in your learning process. As Kriyananda mentioned earlier, repetition is the basis of learning. Since delineation is the key to understanding the natal chart, he has occasionally chosen to expand on the interpretation of one chart through more than one lesson.

For Your Notes

RECORDING 37

Please read pages 368–371
in *The Wisdom and Way of Astrology*

For Your Notes

RECORDING 37

Using the October, 1924 ephemeris below, the assignment that Kriyananda gives you at the beginning of the recording is to draw up a flat chart for a person born October 1, 1924. A blank horoscope wheel is included in this section for you to use. Kriyananda discusses this flat chart in relation to the other chart included in this section.

SIMPLIFIED SCIENTIFIC
EPHEMERIS OF THE PLANETS' PLACES

Calculated for Mean Noon at Greenwich

October, 1924.

New Moon October 28th, 6:57 A. M., in ♎ 4° 35'

Longitude of the Planets

Day	☉	♀	♃	♄	♅	♆	♁	♂	♁	♃	♄	♅		
	♌	♍	♎	♏	♐	♑	♒	♓	♈	♉	♊	♋		
W	18	223	1821	813	121	5514	2625	53	18R47	21	48	20	29	
Th	29	124	2322	5527	392	2	3526	1	45	50	26			
F	310	025	2924	512	5	9	4426	9	43	51	22			
S	410	5926	3525	1026	25	16	5326	19	41	53	19			
Su	511	5827	4127	1510	36	2315	226	28	39	54	16			
M	612	5728	4728	5424	36	30	1226	39	36	56	13			
Tu	713	5629	540	338	262	3715	2126	50	18	3421	57	20	10	
W	814	561	♎12	1622	4	44	3127	02	32	59	7			
Th	915	552	83	585	♋31	51	4027	14	30	22	0	4		
F	1016	543	155	4218	48	58	5027	29	28	2	20	0		
S	1117	544	237	261	♎53	3	516	027	41	26	3	19	57	
Su	1218	535	309	1014	47	12	1027	56	24	5	54			
M	1319	526	3810	5427	28	19	2028	11	22	6	51			
Tu	1420	527	4612	399	♎57	3	2616	3128	27	18	2022	8	19	48
W	1521	518	5514	2322	14	33	4128	43	18	9	45			
Th	1622	5110	316	714	♎19	40	5229	1	16	10	41			
F	1723	5011	1217	5116	16	4717	229	18	15	11	38			
S	1824	5012	2119	3428	8	55	1329	37	13	13	35			
Su	1925	5013	2021	179	♎57	4	2	2329	55	11	14	32		
M	2026	4914	3923	021	50	9	340	♋14	9	15	29			
Tu	2127	4915	4924	423	♎51	4	1617	450	34	18	822	16	19	25
W	2228	4916	5826	2316	5	24	560	55	6	17	22			
Th	2329	4918	828	428	38	3118	71	15	4	18	19			
F	240m	4819	1829	4411	♎35	38	181	37	2	19	16			
S	251	4820	281m	2424	58	45	291	58	1	20	13			
Su	262	4821	383	38	♎48	53	412	21	0	21	9			
M	273	4822	484	4223	45	0	522	43	17	59	22			
Tu	284	4823	586	207	♎41	5	719	43	7	17	5722	23	19	3
W	295	4825	97	5822	31	14	153	30	56	24	19	0		
Th	306	4826	199	357	♎25	22	273	54	55	25	18	57		
F	317	4827	3011	1222	15	29	384	18	54	26	53			

For Your Notes

Chart Interpretation

RECORDING 37

FLAT CHART FOR INTERPRETATION

FLAT CHART
 MALE
 OCTOBER 1, 1924

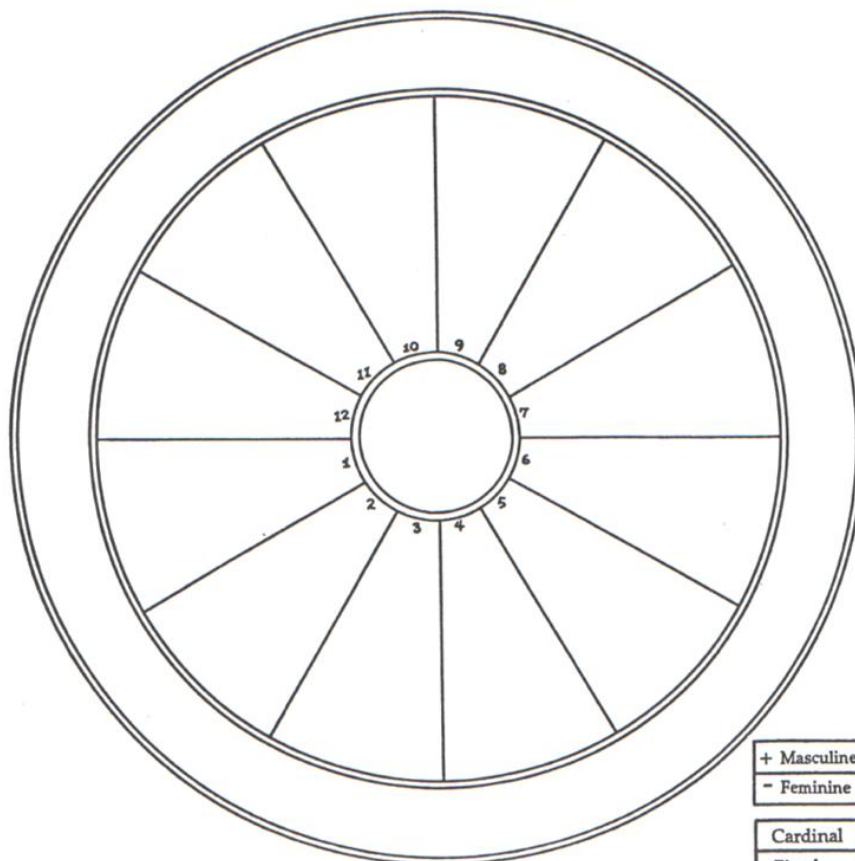

+ Masculine	
- Feminine	
Cardinal	
Fixed	
Mutable	
Fire	
Earth	
Air	
Water	

For Your Notes

Chart Interpretation

RECORDING 37

CHART FOR INTERPRETATION COMPARED TO FLAT CHART

MALE

OCTOBER 1, 1924

6:00 AM CST

PLAINS, GEORGIA

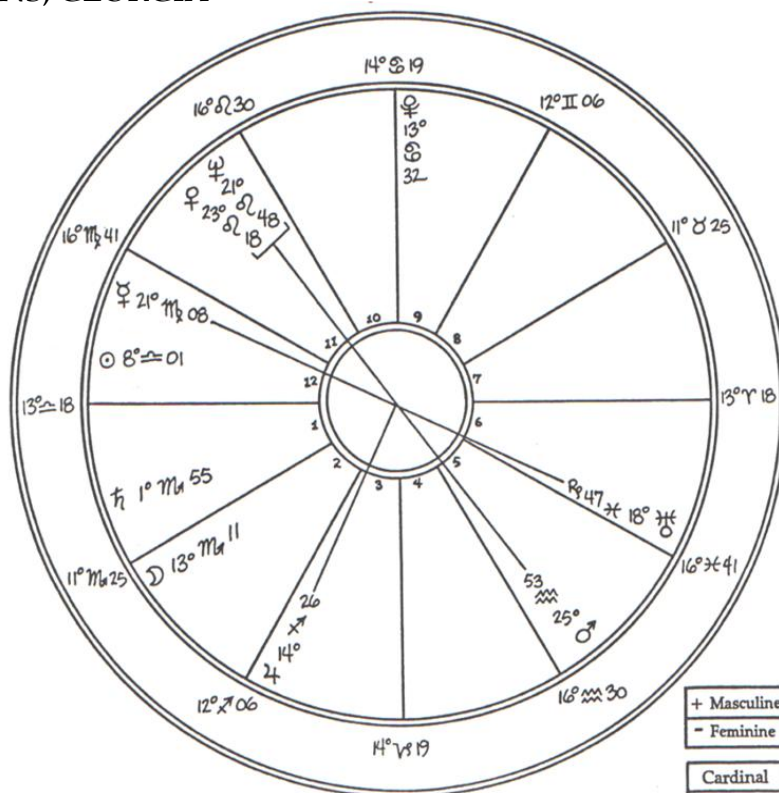

+ Masculine	
- Feminine	

Cardinal	
Fixed	
Mutable	

Fire	
Earth	
Air	
Water	

For Your Notes

RECORDING 38

Please read pages 301–308 and 312–339
in *The Wisdom and Way of Astrology*

For Your Notes

RECORDING 39

Please read page 372 in
The Wisdom and Way of Astrology

For Your Notes

Chart Interpretation

RECORDING 39

CHART 1
 MALE MAY 18, 1920
 7:30 AM CET
 WAD. POLAND
 19 E 55
 50 N 07

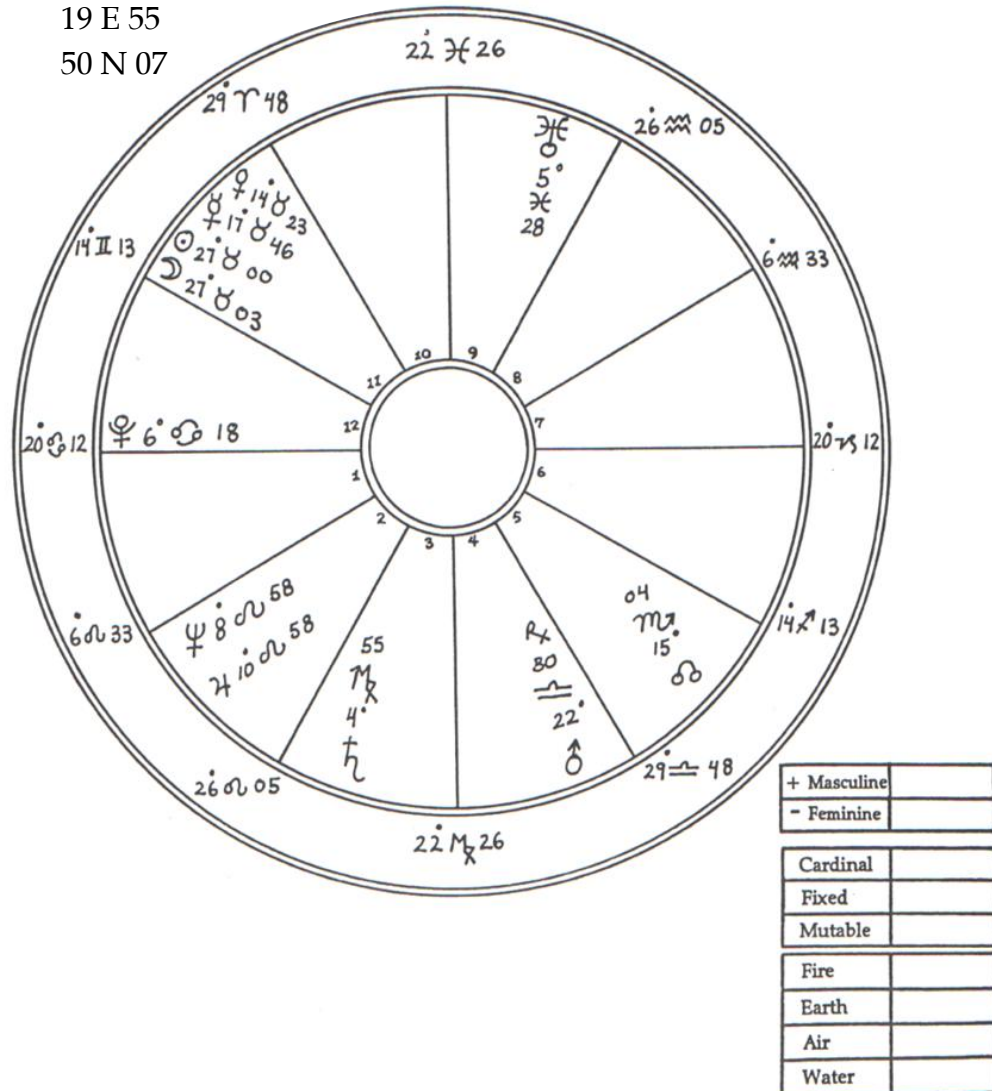

For Your Notes

Chart Interpretation

RECORDING 39

CHART 2

MALE
 OCTOBER 26, 1916
 4:10 AM GMT
 JARNAC, FRANCE
 00 W 11
 45 N 42

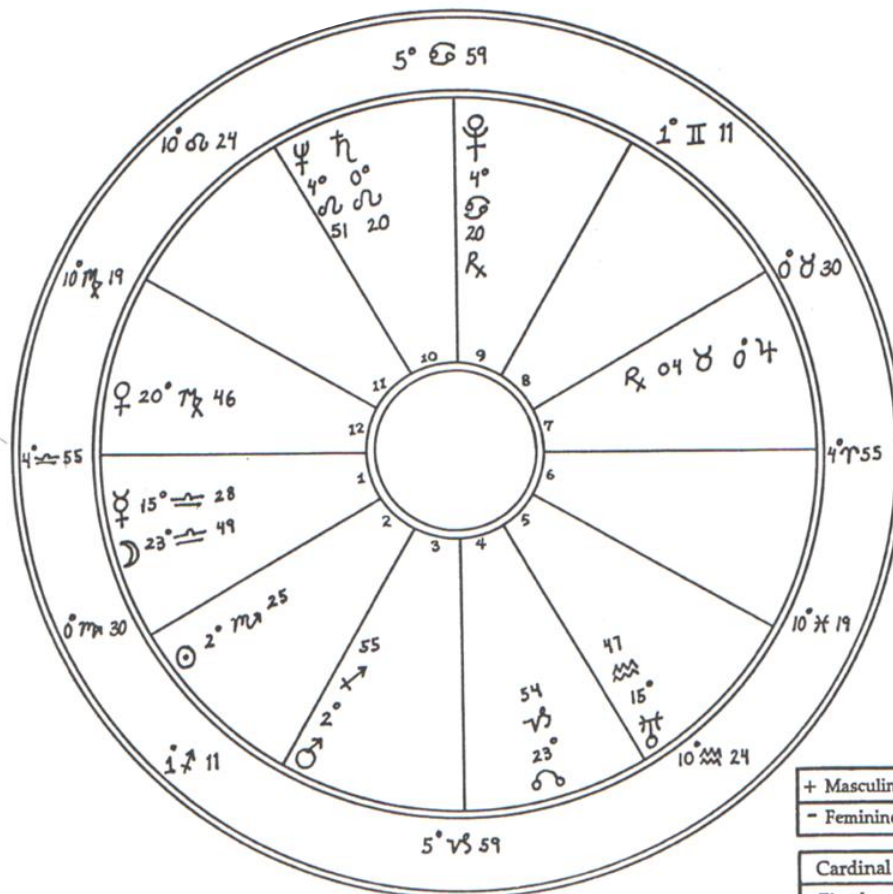

+ Masculine	
- Feminine	
Cardinal	
Fixed	
Mutable	
Fire	
Earth	
Air	
Water	

For Your Notes

When delineating a chart you can begin by interpreting the prominent planets by sign, house and aspect, and then continuing with the remaining planets in the chart.

In the next chapter we will discuss calculations. It is however, my belief that the student's time should be spent in mastering the interpretation of the chart. Later, you can work on the calculations. Therefore, buy your calculated charts from any astrological shop. You give them the data needed and a few dollars. They will give you a computerized chart without errors. They need:

- a) The name of the person (or a code name)
- b) The date, month and year of birth
- c) The time of birth (A.M. or P.M.)
- d) The city and state (or country) of birth

These charts will be correct. There is nothing more destructive (for a beginner) than to try to read a chart which has been calculated incorrectly.

The Temple can calculate your charts. However, you might find that you receive your charts faster if you have a location closer to you. Look in the Yellow Pages for a place that is closer to you. Here is the address, if you decide to use the Temple's service:

For Your Notes

The Temple of Kriya Yoga

2414 N. Kedzie Blvd.

Chicago, IL 60647

(773) 342-4600

Just call or drop us a note, giving us all the data. We will bill you later and postage is free. Each natal chart is \$5.00. Also, remember, your first four charts are free ... yours, and three others.



For Your Notes

This is a blank page.

For Your Notes

How to Become a Practicing Astrologer Self-evaluation Test #11

Please use this chart for Test #11.

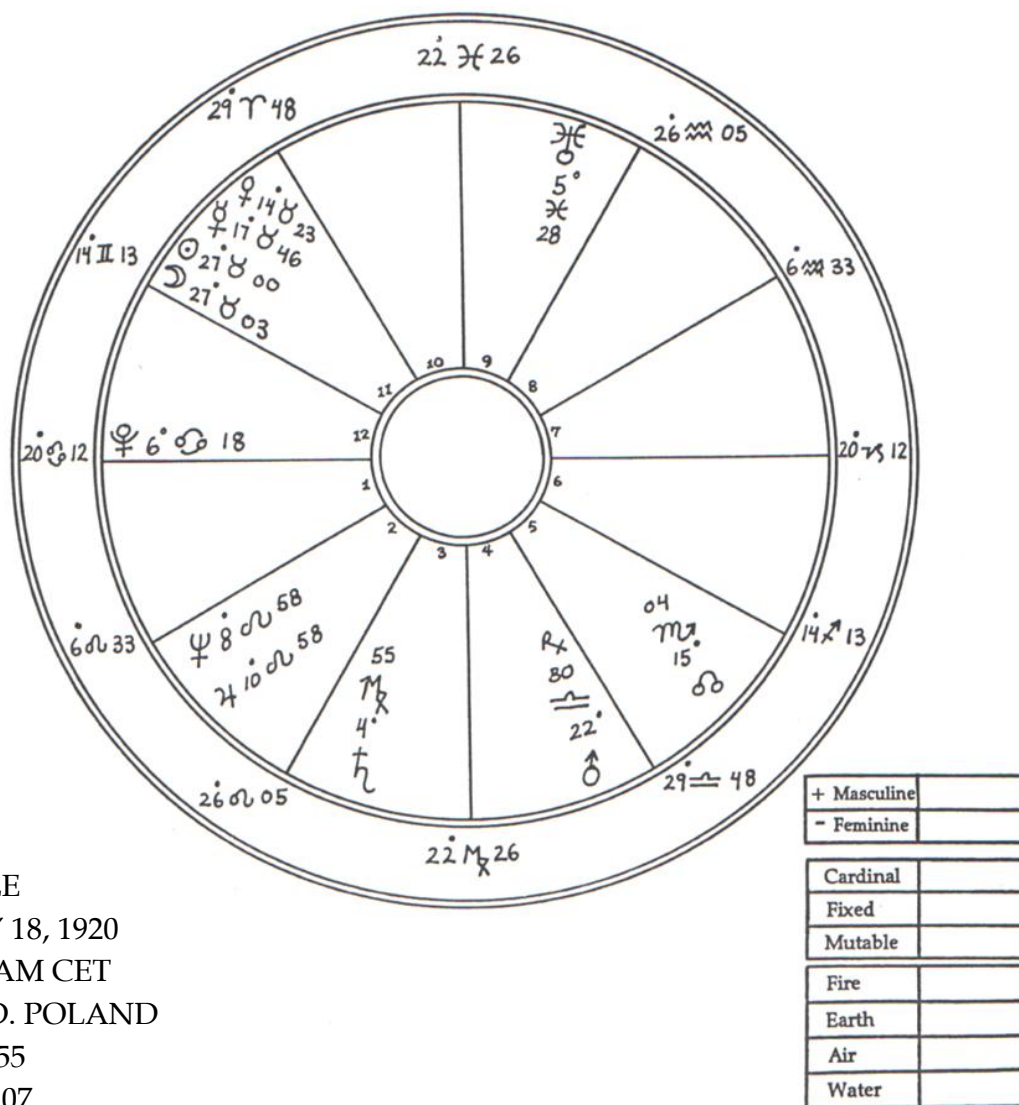

MALE
MAY 18, 1920
7:30 AM CET
WAD. POLAND
19 E 55
50 N 07

For Your Notes

1. Venus is the symbol of cooperation. With whom does this person tend to cooperate easily?

2. Pluto is the planet of motivation and zealousness. In what house is Pluto?

3. In what house do you find the Sun?

4. Which house does Mars rule in this chart?

5. The 7th house symbolizes marriage. Do you feel that this person will marry?

For Your Notes

6. Uranus is the planet of freedom. In what house will he feel his independence most?

7. The 5th house is the house of entertainment and pleasure. In what does the man find pleasure?

8. In general, what area of life does the Sun rule?

9. The planet Mercury tells us what is on a person's mind. In this chart, Mercury is in the zodiacal sign of Taurus. What does the Taurus mind think about?

For Your Notes

10. Which two houses does Venus rule in this chart?

11. Mars is the symbol of accidents, as well as the symbol of instruments of war. Where will this person tend to have accidents?

12. What area of the life is close to this person's soul?

13. Neptune generally tends to fog up or cause areas of confusion. In what house is Neptune?

14. How is this man's vitality?

For Your Notes

15. Which house does Pluto rule?

16. Which house does the Moon rule in this chart?

17. Neptune tends to indicate deception and/or self deception. Is it possible that this person needs to beware of these factors—and, if so, regarding what?

18. The planet of motivation and zealously in the 12th house indicates what?

For Your Notes

19. In this chart which house does the Sun rule?

20. Which two houses does Mercury rule in this chart?

21. Saturn is the symbol of persistency. In what area will the person tend to be persistent?



For Your Notes

How to Become a Practicing Astrologer Self-evaluation Test #12

Please use this chart for Test #12.

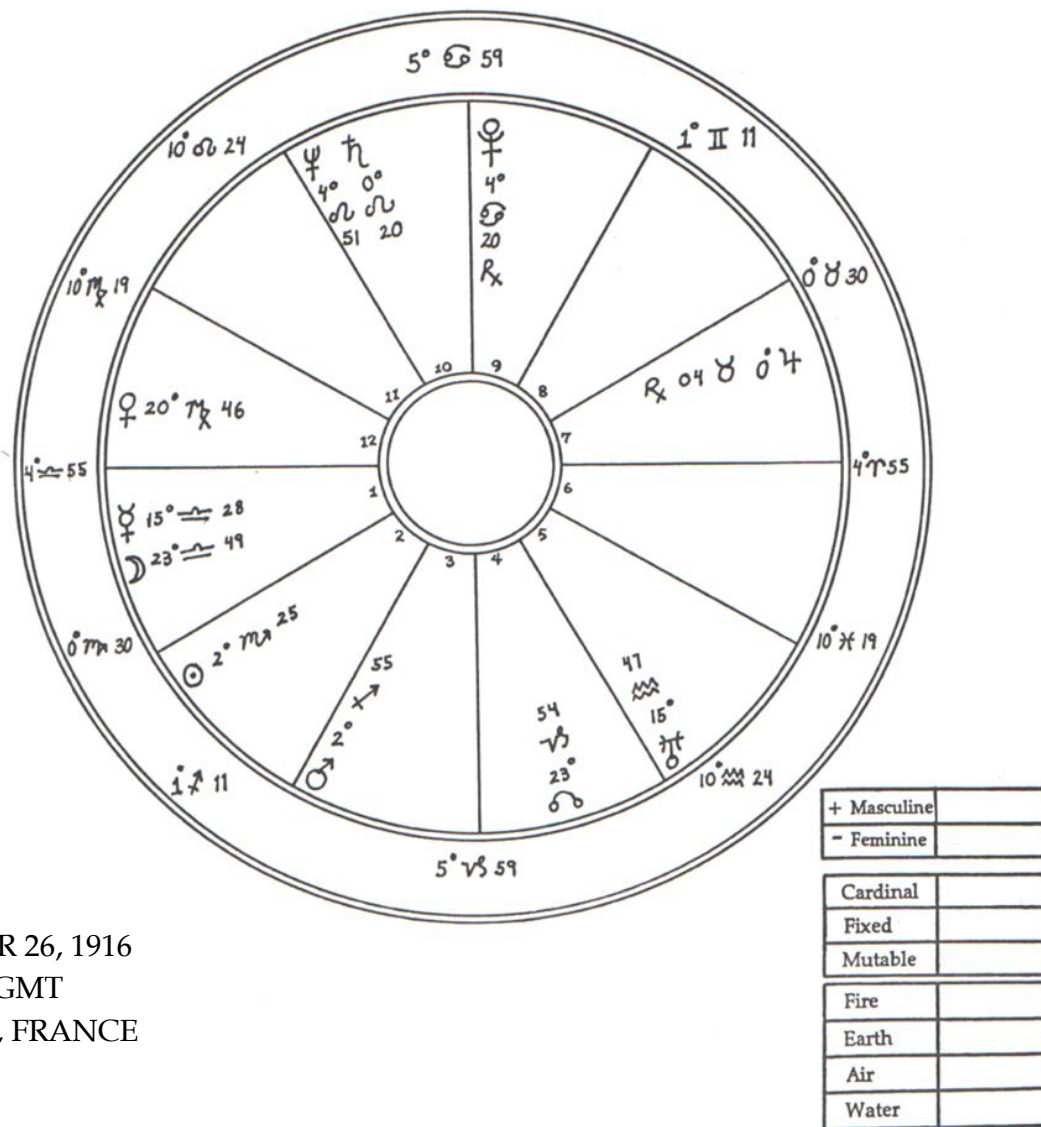

MALE
 OCTOBER 26, 1916
 4:10 AM GMT
 JARNAC, FRANCE
 00 W 11
 45 N 42

For Your Notes

1. What zodiacal sign is this man's Moon?

2. What house cusp symbolizes one's career?

2. Do the planet of desire (Mars) and the planet of duty (Saturn) conflict?

4. What is the strongest planet in the chart?

5. Write out the name for the signs which are on the following cusps:

5th house: _____

For Your Notes

9th house: _____

2nd house: _____

6. Will this man tend to marry?

7. Where is this person curious?

8. What sign is on the cusp of his 10th house?

9. Will this person deal with masses of people or not?

10. In what house is his Moon?

For Your Notes

11. In what house do you find Uranus?

12. What planet formed the pre-natal lunar conjunction?

13. What planet symbolizes potential sickness in this chart?

14. Where do you think this person will tend to be lucky and find ease and expansion of his life?

15. What sign is on the Ascendant?

For Your Notes

16. What planet rules the 9th house?

17. What will most likely motivate this person?

18. Is the ruler of the 9th house well aspected?

19. Is his Sun-sign masculine or feminine?

20. How is the ruler of the 10th house aspected?

21. Is this person's Moon cadent, succedent or angular?

For Your Notes

22. Is Neptune, the symbol of sickness, unfortunately aspected? If so, what is the meaning of this?

23. What planets and/or angles are in masculine signs?

24. What tends to make this person happy?

25. Where does this person need perfect timing?

26. Is his Sun-sign in greater harmony or greater disharmony with the masculine signs?

For Your Notes

27. The 7th house cusp and its ruler describes the wife of this person. In a few simple words, describe the wife.
-



For Your Notes

This finishes the section on delineation for Part 1 of the course: *How to Become a Practicing Astrologer*. The next section deals with calculations. Part 1 is a complete study of the natal chart, in and of itself. A great deal of data regarding life and personality can be gained from it. However, for those of you who wish to study more deeply, I recommend that you take Part 2 of *How to Become a Practicing Astrologer*. It deals with more advanced data regarding the natal chart, as well as with the transits and progressions by which you can know *when* the natal chart will activate in a person's life.

For Your Notes

RECORDINGS 40 AND 41

Recordings 40 and 41 on chart calculations may be disregarded for now. They are here to complete the first part of the course and to give you a better idea of how the chart is put together, if you wish to study them. Kriyananda suggests, however, that the greater amount of your efforts be applied toward chart interpretation at this point.

For Your Notes

CALCULATIONS WORKSHEET
FOR RECORDINGS 40 AND 41

1. Lotta Karma 8/8/81 11:00 PM
Chicago, Ill

2. George Bush 6/12/24 11:30 AM EDT
Milton, Mass 71° W 42° N
Natal = Asc 8° ♍ 20' ♃ 17° ♌ 50'
Progressed 1989 = Asc 28° ♌ 22'
 ♃ 16° ♋ 35'

3. Sandy Beach 9/1/43 12:00 PM
San Diego
Asc 18° ♍ 50' ♃ 0° ♌ 14'

4. Daisy Mae 6/15/50 8:30 AM
Chicago
Asc 3° ♍ 40' or 15° ♍ 26' ♃ 23° ♋ 17'
(Read p. 187 in *Time Changes*)

5. Luigi 5/30/54 4:00 AM
Rome, Italy
Asc 24° ♋ 50' ♃ 9° ♋ 37'

For Your Notes

6. Yoko 3/9/60 10:30 AM
 Kyoto, Japan Zone -9
 Asc 13° ♀ 04' ☽ 28° ♁

7. Terry Cloth 1/21/68 2:10 AM
 Melbourne, Australia 144° E 58' 37° S 45'
 Zone -10
 Asc 16° ♃ 35' ☽ 1° ♌ 56'



For Your Notes

In this class on calculations the instructor refers to reference books for “pages 1 ,2, 3, and 4.”

These books are as follows:

“Page 1” – The ephemeris page for August, 1981. The *Rosicrucian Ephemeris for the 20th Century: Midnight* is used by the instructor.

“Page 2” – A page from a Table of Houses for the Latitudes 40, 41, and 42 North. The *Simplified Scientific Table of Houses* by the Rosicrucian Fellowship is used by the instructor.

“Page 3” – A page of time changes for the state of Illinois. The instructor uses *Time Changes in the U.S.A.* by Doris Chase Doane.

“Page 4” – A page of the Table of Proportional Logarithms. The instructor uses the standard Table found on the last two pages of any yearly *Rosicrucian Ephemeris*.

Please refer to the above books or comparable ones of your choice to aid you in your study of chart calculations.



For Your Notes

14. Constructing the Wheel

RECORDINGS 40 AND 41

Special Time Changes in the U.S.A.

1. The Gregorian Calendar was adopted in the United States on September 14, 1752.
2. Standard time zones were adopted in the United States on November 18, 1983.
3. War Time (W.T.) was initiated in the United States during the First World War. The time change occurred at 2:00 a.m. and applied to the following dates:
 - March 31 – October 27, 1918
 - March 30 – October 26, 1919
4. War Time was observed: From 1942, on February 9th, through September 30, 1945, beginning at 2 a.m.

For Your Notes

5. Daylight Savings Time first occurred in 1920 and ran through 1942, however, it was not universally observed in all cities and all states.
6. From 1946 through 1973, Daylight Savings Time was utilized in various parts of the country.
7. From January 6, 1974, 2:00 a.m., until October 27, 1974, 2:00 a.m., the federal government utilized special emergency Daylight Savings Time. Exceptions were the states of Arizona and Hawaii.
8. In 1936, the state of Illinois observed from March 1st through November 1st, a time change in which they switched from Central Standard Time to Eastern Standard Time to deal with New York City businesses.



For Your Notes

1. Obtain the complete birth data:

Month _____

Date _____

Year _____

Time (A.M. or P.M. must be included) _____

City, State, Country _____

If War Time (W.T.) or Daylight Savings Time (D.S.T.),
automatically subtract one hour. _____

2. Obtain the longitude and latitude of the birthplace

Longitude _____

Latitude _____

3. Convert standard time to Local Mean Time (L.M.T.)

a. Find the difference between the meridian
closest to birth time and birth longitude. _____

b. Multiply this answer (which is in degrees)
by 4 to get minutes (of the clock). _____

For Your Notes

- c. If *east* of meridian, *add* these minutes to the birth time. If *west* of meridian *subtract* these minutes from the birth time. _____
4. Find the Sidereal Time for that birthdate.
(This can be found in the Ephemeris.) _____
5. For P.M. birth *add* the L.M.T. to this Sidereal Time.
(If summation is in excess of 24 hours, subtract 24.)

For A.M. birth, *subtract* the L.M.T. from noon (11:60).

And then *subtract* this answer from your Sidereal Time.

In short, remember an A.M. birth is a double subtraction; P.M. birth is an addition.)

For Your Notes

6. Open the *Table of Houses* at the latitude of the birthplace and find the correct Sidereal Time (that you have calculated). This will give you the “wheel.”
7. Then copy the degrees and the signs that are found in the column (of the arrived at Sidereal Time) for the proper cusps. Only six house cusps will be given in the *Table of Houses*.)

If, for example, your answer for the Sidereal Time was 6 hours, 52 minutes; and the latitude for the place of birth was 41 degrees, north latitude, below is a sample of what you would find in the Table of Houses. You would copy these signs and degrees on the appropriate cusps of the wheel you are calculating.

10th house cusp	12°	Cancer
11th house cusp	15°	Leo
12th house cusp	15°	Virgo
Ascendant	10° 19'	Libra
2nd house cusp	7°	Scorpio
3rd house cusp	8°	Sagittarius

For Your Notes

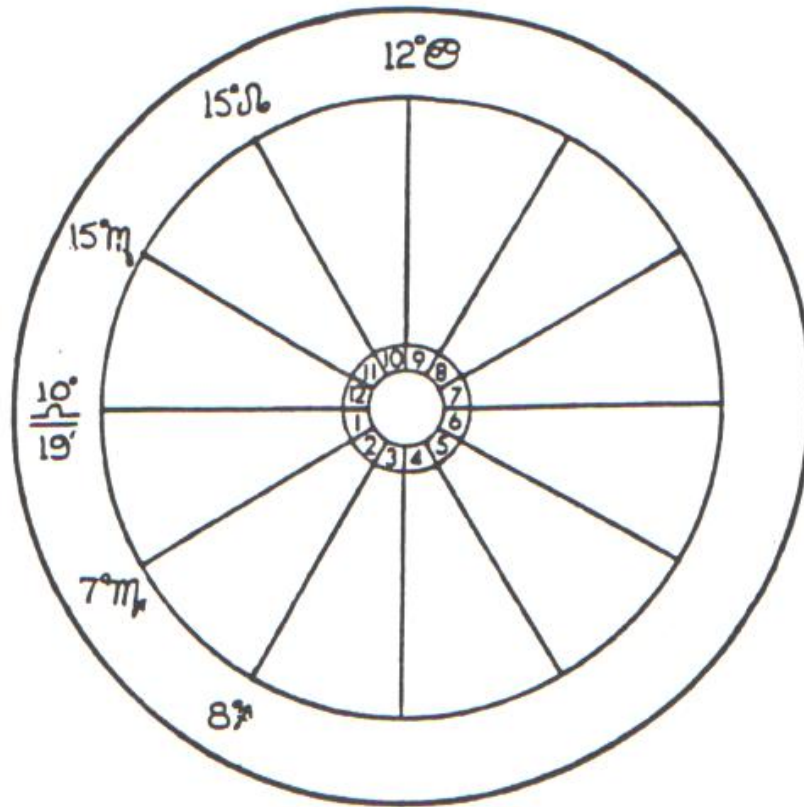

Always check the column being sure that a sign on the cusp did not change!

8. Now, after you have copied the original six house cusps, then fill in the remaining empty cusps by placing the opposite sign from the sign found, along with the degree. Using the above example, we will do this.

For Your Notes

The cusp of the 10th house was 12 degrees Cancer. The opposite of the 10th house is the 4th house, and therefore, the 4th house cusp should read 12 degrees Capricorn.

Secondly, the 2nd house reads 7 degrees Scorpio. The opposite of the 2nd house is the 8th house. Therefore, the 8th house cusp should read 7 degrees of the opposite sign of Scorpio which is Taurus.

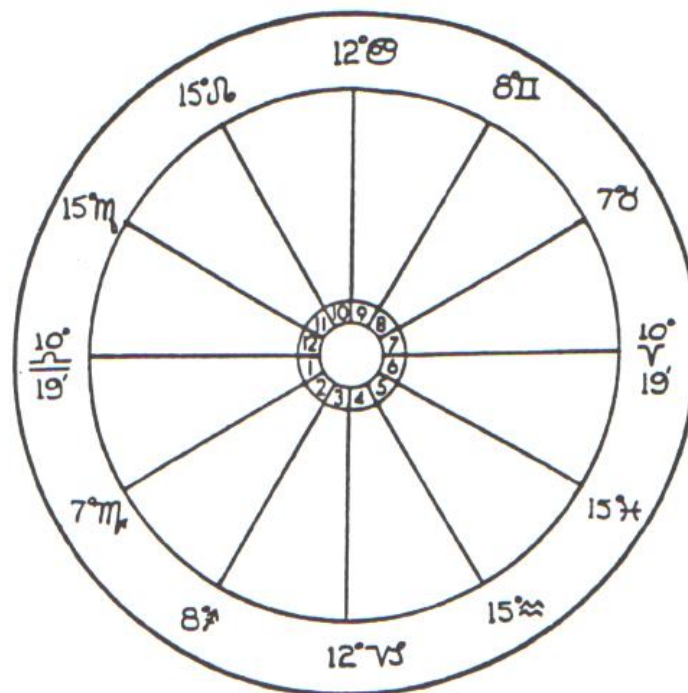

For Your Notes

9. In the *Table of Houses*, only six house cusps are given. For north latitude, the 10th, 11th, 12th, 1st, 2nd, and 3rd houses are given but NOT the 4th, 5th, 6th, 7th, 8th, or 9th. These must be filled in. For south latitude, the 4th, 5th, 6th, 7th, 8th, and 9th houses are given but NOT the 10th, 11th, 12th, 1st, 2nd, or 3rd. Similarly, these must be filled in. Remember, the house cusps that are not given are obtained by placing the opposite signs on the opposite house cusps, but using the same degrees as found in the *Table of Houses*. Remember, Aries is always across from Libra; Taurus is always across from Scorpio; Gemini is always across from Sagittarius; Cancer is always across from Capricorn; Leo is always across from Aquarius; and Virgo is always across from Pisces.

10. Occasionally, there will be the same sign on two house cusps. Be sure to mark down these opposite cusps twice, and also that you insert the missing signs in their proper houses. In short, occasionally a sign does not fall on a cusp, but within a house. This is called an intercepted sign. (See the sample chart with an intercepted sign between the house cusps below. The intercepted sign falls between the following):

For Your Notes

Example:

8th house cusp	26	degrees Virgo
9th house cusp	2	degrees Scorpio
10th house cusp	29	degrees Scorpio

This means that the 3rd house must have Taurus on it (2 degrees), and the 4th house must also have Taurus on it (29 degrees), each with their proper degrees. In this example, as you move from the 8th house cusp to the 9th house cusp, you will notice that you have moved from Virgo to Scorpio and that Libra must be in between these two zodiacal signs. Therefore, Libra is placed *in* the 8th house rather than on the cusp of the 8th house. Consequently, Aries must also be *in* the 2nd house.

For Your Notes

Sample of a Horoscope With an Intercepted Sign

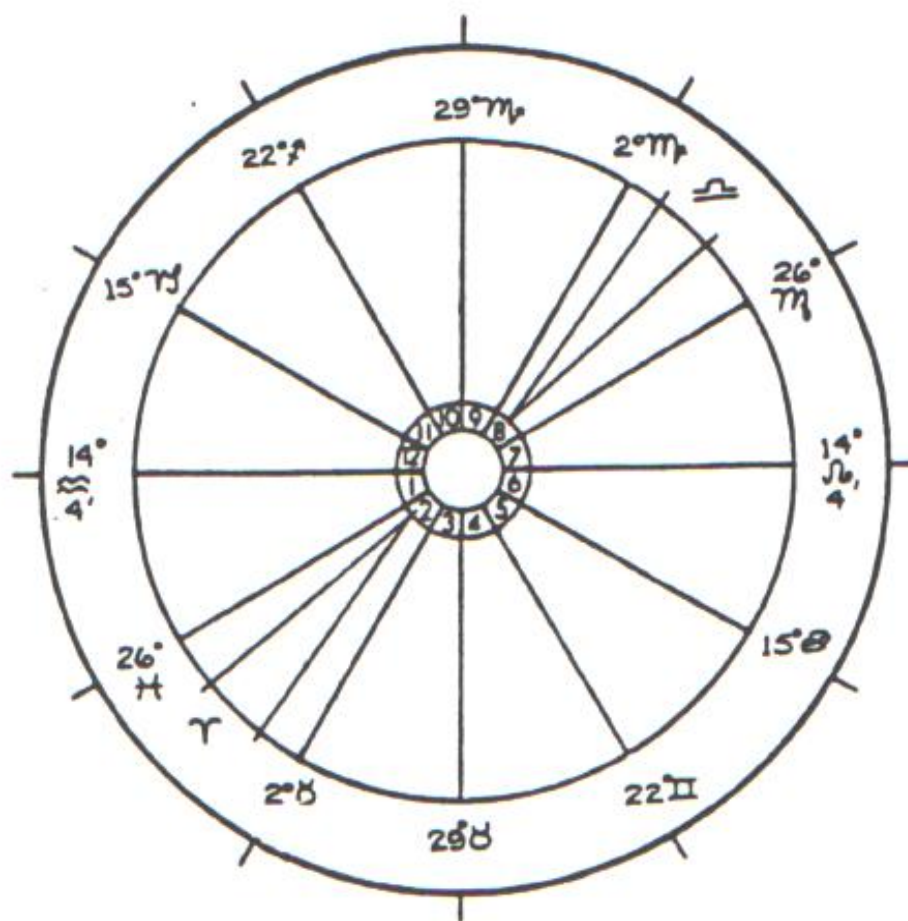

For Your Notes

15. *Placing the Planets in the Chart*

RECORDINGS 40 AND 41

Now that you have learned how to obtain the house cusps, we will next outline the steps necessary in order to place the planets correctly in the horoscope.

1. The first step is to calculate the Noon Mark. You find the Noon Mark by:
 - a. Dividing the longitude of the birthplace by 5 hours 15 degrees; this gives you hours.
 - b. Multiply any remainder by 4, which gives you the minutes.

This example gives you 5 hours 52 minutes.

5 hours
15) 88 longitude
75
13 remainder
x 4
52 minutes

For Your Notes

- c. Subtract this time from noon (11:60).

$$\begin{array}{r} 11:60 \\ - \underline{5:52} \\ 6:08 \end{array}$$

The answer is the Noon Mark for this birthplace.

- d. If the birthplace is *west* of Greenwich, the Noon Mark is
A.M.

If the birthplace is *east* of Greenwich, the Noon Mark is
P.M.

Chicago has a longitude of 88 degrees. The Noon Mark for the city of Chicago is 6:08 A.M. (because Chicago is west of Greenwich). This means that when it is noon in Greenwich, it is 6:08 A.M. in Chicago. Knowing this allows you to find the correction from the Ephemeris in which all planetary positions are calculated for noon Greenwich. [Note: If you are using a Midnight ephemeris there will be different calculations.]

For Your Notes

2. Determine whether birth occurred *before* or *after* noon mark.
 - a. If a person was born *after* noon mark, you need each planet's position for the day of birth AND the day after. Subtract the difference to determine the distance the planet moved during the 24-hour period. For example:

Moon position, day <i>after</i> birth	24°	Leo 48"
Moon position, given birth day	- <u>10</u> °	Leo 48"
Distance planet moved:	14°	

If a person is born *before* Noon Mark you will need the planet's position on the birthday as well as on the day *before*. For example, if the person is born on March 3rd but was born before Noon Mark, then you must find the planet's position for the birthday and also for March 2:

March 3rd, Moon position	15°	Aries (given birthday)
March 2nd, Moon position	- <u>1</u> °	Aries (day before birth)
Distance planet moved:	14°	

For Your Notes

In short, the difference between the planet's motion on these two days is the planet's motion for one day (which is a 24-hour period).

3. Find how many hours exist between the birth time and the Noon Mark.

- a. If born *after* Noon Mark, the proportional hours of the day are *added* to the planet's position on the birthday.

For example, if the Moon has travelled 12 degrees in one day and the person was born 12 hours *after* Noon Mark, the Moon has travelled 12/24's or a half a day. This is half of the 12 degrees and thus 6 degrees is added to the birth position of the Moon.

If the person was born with his Moon (on his birthday) at 3 degrees Sagittarius, you would add 6 degrees. Thus his **actual corrected birth position of the Moon** would be 9 degrees Sagittarius.

- b. If a person was born *before* the Noon Mark, the proportional distance traveled should be *subtracted* from the planet's position of the day of birth.

For Your Notes

For example: the Moon on the birthday is 10 degrees Aries. If the Moon moved 12 degrees and the person was born 6 hours *before* Noon Mark, then the planet has moved 6/24's of the day. Consequently, 6/24 is 1/4 of a day. This is 1/4 of the 12 degrees, or 3 degrees.

Therefore, if the person was born before Noon Mark you would *subtract* the 3 degrees from the birth position of 10 degrees Aries, giving the corrected Moon position as 7 degrees Aries.

NOTE: If a planet is retrograde, the above processes are reversed. That is to say:

If retrograde and born *before* noon mark you *add*.

If retrograde and born *after* noon mark you *subtract*.

(The Sun and Moon never go retrograde.)



For Your Notes

Correction Factors

To correct the planet's position with great accuracy, the use of logarithms is necessary. Over and above this, two subtle corrections are needed:

1. The first is the correction between the Local Mean Time and noon.
2. The second is the correction for longitude of the birthplace.

When the birth time is known to be quite correct, then there is a correction that needs to be made between Local Mean Time of birth and noon. This is done by finding the difference between the birth time and noon. A correction rate of 10 seconds is made for every hour of difference between the Local Mean Time of birth and noon.

If the birth occurs before noon, *subtract* the correction seconds from the Sidereal Time.

If the birth occurs after noon, *add* the correction seconds to the Sidereal Time.

For Your Notes

This means that for every hour, a 10-second correction is needed. This means for each 6 minutes differentiation, a 1-second correction is needed. Therefore, you realize if you had 4 hours and 42 minutes, the 4 hours would give you 40 seconds and the 42 minutes would give you 7 seconds (6 into 42 is 7). If this were after Noon Mark, you would add this to the Sidereal Time.

The second factor necessary for accurate correction is a correction to Sidereal Time because of the longitude of your place of birth. Change the longitude of birth into time by dividing by 15. The answer you have obtained is the time difference between the birthplace to Greenwich. For every hour of this time difference, allow 10 seconds. For every 6 minutes of clock distance, correct by 1 second.

If the longitude of the birthplace is west of Greenwich, add 10 seconds for every hour and 1 second correction for each 6 minutes, to the Sidereal Time.

If the longitude of the birthplace is east of Greenwich, subtract 10 seconds for every hour east and 1 second for each 6 minutes, to the Sidereal Time.



For Your Notes

Logarithms

Logarithms are a means for correcting planetary places from the Noon Mark to the corrected place according to birth time. When you desire very precise work, the planetary positions can be corrected quite accurately by means of logarithms. A table of logarithms is found in the back of each and every Ephemeris.

Add the proportional logarithms of the planet's daily motion to the logarithm of the amount of time born from Noon Mark. These two logs must always be added!

Add this derived motion to the planet's given place found on the birthdate if born *after* Noon Mark. *Subtract* this derived motion if born before Noon Mark from the position of the planet in the Ephemeris. (Reverse this procedure for retrograde motions.)

For example, if the Moon on December 3rd was 14 degrees Scorpio 11 minutes, and on December 4th it was 28 degrees Scorpio 30 minutes, you simply find the planetary difference which is 14 degrees 19 minutes. The log for 14 degrees 19 minutes is .2244.

If a person was born 4-1/2 hours after Noon Mark, you find the log for 4 hours 30 minutes. That log is .7270.

For Your Notes

These two figures are then added together:

.2244

.7270

0.9514 is the logarithm needed that is the derived motion.

Remember, these two logs are always added together.

Looking into the table of logs, the nearest logarithm we can find is 0.9515. Converting that log back into motion, we find that it is equivalent to 2 degrees 41 minutes. This is added because the person was born after Noon Mark.

On his birthday, December 3rd, the Moon's position was 14 degrees Scorpio 11 minutes. We now add the derived motion, 2 degrees 41 minutes, and find out that the Moon's accurate and precise correction for that time of birth is 16 degrees Scorpio 52 minutes.

It's obvious that the motion of the slower moving planets simply cannot be computed by logarithms and the mental equation is needed.

In summary, here is the rule:

For Your Notes

CORRECTING THE PLANETS' POSITIONS BY LOGARITHMS

Rule:

1. Add proportional log of the planet's daily motion to the log of the amount of time born before Noon Mark. Add these two logs together.
2. The sum will be the motion required. *Add*, if born *after* Noon Mark. *Subtract*, if born *before* Noon Mark.
3. Reverse for retrograde motions.



For Your Notes

CHART CALCULATION SHEET FOR NOON EPHEMERIS

NAME _____ BIRTH DATE _____ HOUR _____ ^{A.M.}_{PM.}
 BIRTHPLACE _____ LATITUDE _____ LONGITUDE _____

TRUE LOCAL TIME

Birth Hour according to Standard Time _____
 Add or Subtract Longitude correction from book _____
 Result is True Local Time _____

H	M	S

A.M./P.M.
A.M./P.M.

SIDEREAL TIME

Sidereal Time at Greenwich for Noon previous to T.L.T. _____
 Correction of 10 sec. for each 15 deg. Of Long. _____
 (convert minutes to decimal equivalent and divide by 15.
 add if west long. – subtract if east long.)

Interval between previous Noon and T.L.T. _____
 Add correction of 10 sec. for each hour of interval _____
 ADD above four figures and result is Sidereal Time at
 birthplace at birth hour. Look up this figure in Table of Houses _____

GREENWICH MEAN TIME

Take birth hour according to Standard Time and add or
 Subtract appropriate time zone increment _____
 Interval in hours & minutes to the nearest Noon _____
 Logarithm for this interval equals Permanent Logarithm _____

G.M.T.
A.M./P.M.

POSITIONS OF THE PLANETS

♄ ♃ ♀ ♁ ♀ ♂	☉	☾	☿	♀	♂	JUPITER ♃
♄ ♃ ♀ ♁ ♀ ♂	☉	☾	☿	♀	♂	SATURN ♄
Sign placement						URANUS ♅
Coming Noon Position after G.M.T.						NEPTUNE ♆
Previous Noon Position before G.M.T.						PLUTO ♇
Distance traveled						NORTH NODE ☾
Logarithm of travel						☉
Permanent Logarithm						
Sum of logarithms						
Convert above to deg. & min. Add to prev. Noon if G.M.T. is P.M. – Sub. from coming Noon if G.M.T. is A.M.						

For Your Notes

This is a blank page.

For Your Notes

Glossary of Basic Astrological Terms

ACCIDENTAL DIGNITY occurs when a planet is found in an angular house. The strongest placement for accidental dignity is the 10th house. The next strongest is the 1st house, then the 7th house and, lastly, the 4th house placement, which is the weakest. After this, a planet in a succedent house is next in strength. Planets found in the cadent houses are weakest of all.

The old astrologers of a few hundred years ago pointed out that a planet is accidentally dignified when it is sextiled or trined the Part of Fortune, or when it is aspecting a benefic, or when swift in motion, or when it is in a house ruled by the sign that the planet rules, i.e., the Sun in the 5th house, the 5th house being ruled by Leo, that planet is accidentally dignified in the 5th house. Modern astrologers, however, usually confine the use of the term 'accidental dignity' to one factor: that planet that is highest in elevation.

AFFLICTED: A planet is afflicted when it has inharmonious aspects, generally the square, the opposition, or a negative conjunction; i.e., conjunction with negative planetary forces such as Mars, Saturn, Uranus, Neptune or Pluto.

For Your Notes

AIR SIGNS: Air signs are those signs that deal with the mental or intellectual side of consciousness, i.e., Gemini, Libra and Aquarius.

ANARETA: Any planet that is so placed in the horoscope by position or aspect, that it tends to shorten the length of life.

ANGLES: The term for the cusps of the 10th, 1st, 7th or 4th houses.

ANTISCION (plural = antiscia): A term first used by the ancient astrologer, Ptolemy (the 'P' is silent). It refers to any two planets which have the same declination, on the same side of the equator. If two planets have the same declination, but are on the opposite sides of the equator it was termed contra antiscion.

APHELION is the point on a planet's orbit furthest from the Sun.

APHETA refers to a planet, or a degree, that exercises marked influence over the duration of life.

For Your Notes

APOGEE is that point in a planet's orbit that is furthest from the center of the earth. All motions of the planets, astrologically as well as astronomically, are 'apparent motions' from the position of an observer on earth. One speaks of the planetary motions in terms of what they appear to be, rather than what they are. For example, in meteorology the west wind personifies the wind that comes out of the West, but it is actually blowing to the East.

APPLICATION refers to a celestial body in motion towards a point where it will aspect another planet or astrological point, such as a house cusp.

ARABIAN PARTS: In the Middle Ages the Arabians perfected their Astrology by formulating three measurements of the horoscope. These usually consisted of two planets and the Ascendant. This formulation revealed a point that synthesized the two planet's relationship, in terms of the Ascendant. These points were called Parts. The Arabian Parts symbolized that the Arabians clearly understood the value of Solar houses; i.e., establishing the Sun's degree as the Ascendant and projecting 12 houses of equal arc (of 30 degrees). The Arabian Parts are of great value when properly understood. Today, more Western astrologers are turning toward harmonics instead.

For Your Notes

ARC: A segment of a curved line of a circle or an ellipse. It reveals the orbital distance separating two planets or two astrological points.

ASCENDANT: The degree of the zodiac that appears on the Eastern horizon at the moment of birth, of a person or an event. Today it is oftentimes loosely applied to the whole zodiacal sign that is rising rather than to that degree.

ASCENDING PLANET: The rising of any given planet from the Ascendant in the direction of the Midheaven.

ASPECT: The ancients referred to an aspect as ‘familiarity’ or configuration. An aspect is a certain angular distance between any given planet and any other planet or point in the horoscope.

ASTERISM: A constellation. It is sometimes applied to a zodiacal sign, but should really only apply to the 3 signs of the same element when considered collectively. In certain types of astrology, ASTERN refers to the lunar constellation as opposed to the solar zodiacal constellations.

For Your Notes

ASTEROID: The meaning of the word is 'little planet.' There are many thousands of planetary fragments, the vast majority being called planetoids. They exist between the orbit of Mars and Jupiter. The largest of these range approximately 500 miles in diameter ... a few are only a few miles in diameter. Most measure downward to a fraction of a mile. Asteroids can be very meaningful, and modern astrologers have utilized *Ceres*, *Pallas*, *Juno* and *Vesta*, as well as *Lilith*, which although called the dark Moon is really Asteroid #1181.

ASTROLOGY: The science that deals with the influence of the celestial bodies upon all life forms.

ASTRONOMICAL UNIT is a measurement equaling the mean distance between the earth and the Sun which is approximately 93,000,000 miles. Therefore 93,000,000 miles equals one astronomical unit, abbreviated 1 AU.

ASTRO-TWINS refers to two people born of a different mother but in a time-space relationship to one another which causes their horoscopes to become very similar. For some astrologers this science of astro-twins is

For Your Notes

the beginning of trying to clearly show the difference between karma and the aspects or astrological gates which allow in that karma.

ASTRONOMY: The science that deals with the nature and position of all the heavenly bodies, as well as their motions and sizes. More and more astronomy is beginning to deal with the effect of the heavenly bodies upon the earth's weather, and communications, as well as bumper crops in agriculture, and also business cycles.

AYA-NAMSA. Aya-namsa refers to the arc of difference between the tropical zodiac and the sidereal zodiac. The tropical zodiac is based upon the Sun's ingress into Aries. The sidereal zodiac is based upon the reference to a fixed star. Aya-namsa needs to be calculated in order to convert from Western astrology to Hindu astrology, or to convert from tropical measurements to sidereal measurements. The aya-namsa is approximately 24-1/2 degrees behind the tropical longitude. The distance between the tropical and sidereal increases by approximately 50 seconds per year. Thus, in 1995 the difference is 24 degrees 42 minutes. Therefore, a planet in 19 degrees 42 minutes Aries in a Western chart would be in 25 degrees Pisces in a sidereal or Hindu chart.

For Your Notes

BARREN SIGNS: Gemini, Leo and Virgo are considered to be barren signs because they tend to inhibit fertility. Some astrologers indicate that there is a tendency for Sagittarius and Aquarius to be semi-barren signs.

BENEFICS: The ancients considered Venus and Jupiter to be benefics. Venus is known as the lesser benefic, and Jupiter as the greater benefic.

BESTIAL SIGNS. Those signs symbolized by animals: Aries, Taurus, Leo, Scorpio, the last half of Sagittarius, as well as the last half of Pisces.

BICORPOREAL SIGNS. The doubled bodied signs: Gemini, Sagittarius, and Pisces. Ptolemy employed this term, whereas modern Astrologers use the term 'mutable.'

CADENT: Those houses which fall away from the four angles. Thus, the cadent houses are the 3rd house, the 6th house, the 9th house and the 12th house. Generally speaking, planets in cadent houses weakly influence the external life of the native, according to some astrologers.

For Your Notes

CAPUT DRACONS is the Dragons Head, referring to the North Node of the Moon.

CARDINAL SIGNS: Aries, Cancer, Libra and Capricorn.

CAUDA DRACONS is the Dragon's tail, or the South Node of the Moon.

CAZIMI: When a planet is conjunct the Sun by only 17 minutes of arc it is called cazimi, which means that the most favorable qualities of the planet manifest. See Combust.

CELESTIAL EQUATOR is the extension of the earth's equator out into space, forming the celestial equator. It is always perpendicular to the earth's axis.

COLD PLANETS: The Moon and Saturn; and according to some astrologers, Mercury and Uranus.

For Your Notes

COMBUST: A planet is combust when it is in conjunction to the Sun. Some Astrologers limit this to 3 degrees, other to 9 degrees. The theory of combust is that the power of the Sun burns up the positive qualities of any planet that it is conjunct. See Cazimi.

COMET: Comets are small bodies circulating around the Sun. They are visible only as they approach the Sun. Different astrologers give different significance to the comets. Some say they are indicators of the birth of a great soul; others say it is the indicator of the death of a great soul. Shakespeare said, 'When beggars die there are no comets seen. The heavens themselves however blaze forth the death of princes.' The births of President Theodore Roosevelt and also of President Franklin D. Roosevelt were marked by extremely brilliant comets. The death of Mao Tse-Tung was marked by a comet.

COMMON SIGNS. Those of the mutability group: Gemini, Virgo, Sagittarius and Pisces. Common or mutable signs are said to cause the urges of the planets, therein contained, to be more mutable.

CONJUNCTION: A conjunction occurs when two planets occupy the same longitudinal position separated by no more than 7 degrees (for the

For Your Notes

large planets and Lights), and no more than three degrees for the smaller planets.

CONSTELLATIONS: There are some 90 constellations in the heavens, mostly named according to ancient outlines of the stars. Those constellations existing in or along the ecliptic are known as the constellations of the zodiac, or the zodiac. There are only 12 zodiacal signs.

CO-RULER: Any planet that exists beyond the orbit of Saturn not visible to the naked eye. During the last 300 years the astronomers and astrologers have discovered a number of new planets invisible to the naked eye. Among these are Uranus, Neptune and Pluto. Thus, Uranus became a co-ruler of Aquarius. Neptune became the co-ruler of Pisces. Pluto became the co-ruler of Scorpio.

CRITICAL DEGREES: One of the ancient systems was to measure the horoscope's mansion, based on the average motion of the Moon which is approximately 13 degrees per day. Therefore, starting with 0 degrees of Aries, a new lunar mansion was created. The beginning of each new mansion segment is considered the critical or intense degree. Thus 0, 13

For Your Notes

and 26 degrees in cardinal signs were marked as critical. The 19 and 21 degrees of the fixed signs were critical, and 4 and 17 degrees of the mutable signs were critical. Planets placed in or near these critical degrees took on added intensity, just like a planet on the cusps of the solar houses.

CULMINATION: When a planet arrives at the midheaven or the cusp of the 10th house, it is considered to culminate. This gives great energy to that planet and great power in that person's life and/or career.

CUSP: The theoretical point at which one sign ends and another begins. The conceived point separating the ending of one house and the beginning of another house.

CYCLE: The time that it takes for a planet or the luminaries to return to their own place. Each planet has a cycle or revolution of its own duration. For example, the Moon's cycle is 19 years and the Sun's cycle is 28 years.

For Your Notes

DAYLIGHT SAVINGS TIME {DST}: Started in England in the year 1916. It is also called Summer Time. DST consists of moving the clock forward one hour during the summer months, and putting the clock back during the winter months. In other words: Spring forward, Fall behind. Originally, this concept was to give people more time in the summer for evening recreation. Generally, DST begins at 2:00 A.M. on the Sunday following the third Saturday in April, and ends on the Sunday at 2:00 A.M. after the first Saturday in October. However, this is not a reliable guide because DST oftentimes changes from year to year, both in England and in the United States. For example, during the war, England introduced 'War Time' or double Summer Time. In the United States, War Time was established during all 12 months. Also, different countries started using Daylight Saving Time during different years. If birth time is Daylight Savings Time, one hour must be subtracted from that birth hour to bring it to Standard Time.

DEBILITY: A term used to indicate that a planet has a weakened nature due to the house or sign position, etc.

DECAN: Also known as DECANATE and indicates a subdivision of each sign into three parts of 10 degrees each.

For Your Notes

DECLINATION: Is a second type of measurement, the first measurement being longitudinal. Declination is the distance north or south of the celestial equator. When two or more planets are within 1 degree of a declination, either north or south, they are in Parallel of Declination or Contra-parallel of Declination. A Parallel of Declination, when both planets are on the same side of the equator (either north or south), acts as a long lasting conjunction. When the two planets are on the opposite sides of the equator, they act as a long lasting opposition.

DECREASING IN LIGHT: As the Moon moves from Full Moon to New Moon it is decreasing in light. When the Moon is decreasing in light, it is the best time to work on the inner planes and with the inner worlds. Some astrologers believe that when the Moon is decreasing in light, it loses some of its strength (to function in the external world).

DESCENDANT: The cusp of the 7th house, or the Western angle. It has begun to take on the meaning of the whole 7th house.

DETRIMENT: The placement of a planet in the opposite sign than that planet rules.

For Your Notes

DEXTER ASPECT: The word dexter in Latin means 'right.' This is opposed of a sinister aspect, which in Latin means 'left.' A dexter aspect is an aspect that is applying to another planet. In a sinister aspect, the planet is separating or departing from the planet it has already aspected.

DIRECT MOTION: The term direct means that a planet is moving in its apparent motion, counterclockwise, which is the normal longitudinal movement. The opposite of direct motion is retrograde motion, in which a planet appears to be moving clockwise. Also, direct motion means to progress a planet or to move a planet forward to a new position beyond that which it had in the natal chart.

DEPOSITOR: The ruler of the sign on the cusp of any given house, which disposes of all planets positioned inside that house.

DOUBLED BODIED SIGNS: Also referred to as BI-CORPORAL SIGNS. These signs are known as Gemini, Sagittarius and Pisces.

For Your Notes

DRAGON'S HEAD: An ancient term for the North Lunar Node. The dragon's tail is an ancient term for the South Lunar Node. The Latin term is 'Caput Draconis'—the head of the dragon. 'Cauda Draconis' is the tail of the dragon.

EARTH SIGNS: Also referred to as the earth triplicity and is a symbol of practicality. They are the signs Taurus, Virgo, and Capricorn.

EAST POINT: The true horizon of the earth, when it is established in reference to the equator. East point is also referred to as the equatorial ascendant. It is actually that point where the earth's equator joins the ecliptic.

ECLIPSE: Is the darkening or the occultation of either the Sun or the Moon. A solar eclipse occurs when the Moon is between the earth and the Sun and both are on, or near, its nodal axis. An eclipse of the Moon occurs when the earth is between the Sun and the Moon and the luminaries are on, or near, the nodal axis. There are three types of eclipses: total eclipses, partial eclipses and annular eclipses.

For Your Notes

An eclipse of a planet (or of a star) can occur when the Moon comes between the earth and that body. This is called an occultation. An eclipse of a planet can also occur involving the Sun, the earth and a planet. However, this is rare.

ECLIPTIC: The apparent path of the Sun. It is also referred to as *Via Solis* - the Sun's path.

ELECTIONAL ASTROLOGY: A method by which an astrologer chooses the best suitable time for the beginning of a project, such as a marriage, a job, or a journey.

ELEMENTS: The four fundamental astrological forces: Air, Earth, Fire and Water.

ELEVATION: The distance of a planet above the horizon. An elevated planet when it is near the Midheaven brings about the release of greater strength due to this elevation. In short, the higher the elevation, the more influence the planet releases.

For Your Notes

ELONGATION: Elongation is the angular distance of a planet from the Sun as viewed from the earth. The maximum elongation of Mercury is 28 degrees; the maximum elongation of Venus is approximately 46/48 degrees. Consequently, in a natal chart the only aspect that Mercury can form to the Sun is a minor aspect called a semi-sextile (30 degrees). In a natal chart Venus can only form two minor aspects to the Sun: the semi-sextile (30 degrees), or the semi-square (45 degrees).

EPHEMERIS: The plural is ephemerides. It is a book listing the changing positions of each of the planets on a daily basis. An ephemeris includes the planetary longitudes, latitudes and declinations of the planets, as well as the lunations and eclipses. The old astronomical day, which began as noon, was discontinued on January 1, 1925. Since that time the astronomical day begins at midnight (00:00:01 A.M.).

EQUAL HOUSE SYSTEM: A house system calculated from the Ascendant with each house cusp being exactly 30 degrees. If the Ascendant were 21 degrees Aries, 27 minutes, the 2nd house would be Taurus, 21 degrees, 27 minutes. The 3rd house would be Gemini, 21 degrees, 27 minutes, etc. In the equal house system, an intercepted sign is impossible.

For Your Notes

EQUATOR: The plane that is perpendicular to the earth's axis. The celestial equator is the extension of this equatorial plane.

EQUINOX: A point in the earth's yearly orbit around the Sun in which the earth's polar inclination is at right angles to the Sun. Consequently the length of the day and the night are equal. There are two equinoxal points. One is called the Vernal Equinox occurring on March 21, when the Sun enters 0 degrees Aries. The other is called the Autumnal Equinox occurring on September 22, when the Sun enters 0 degrees Libra.

EXALTATION: Refers to a planet's dignity, or the positive force of a planet given when the planet is in a particular house or sign.

FALL: A planet is in Fall when it is in the sign opposite the sign of its exaltation.

FEMININE SIGNS: The even numbered signs, or the earth and water signs: Taurus, Cancer, Virgo, Scorpio, Capricorn and Pisces. Planets in

For Your Notes

feminine signs tend to cause the person to be more introverted. Energy released from these planets is mostly directed inward.

FIRE SIGNS: Aries, Leo, Sagittarius. People who have many planets in fire signs tend to be more enthusiastic and generate energy very easily.

FIRST POINT: The first point is 0 degrees Aries. It is from this point that longitude is reckoned along the ecliptic, and that the right ascension is also reckoned—calculated along the celestial equator.

FIXED SIGNS: Taurus, Leo, Scorpio, Aquarius.

FIXED STARS: Some of the fixed stars which act as a back drop to the horoscope and are vital to the interpretation of certain destinies of advanced souls. Although they are called fixed stars they do move. Their motion is approximately 50 seconds of arc each year (not minutes of arc). Fixed stars have the nature of one or more of the planetary energies.

For Your Notes

FOCAL POINT: A reference point which focuses the symbolism in a natal chart, revealing its most vital and pointed force-field. Generally, there is only one focal point in each chart. There are, however, many different types of focal points. For example: singleton, the final dispositor, a stellium, or a hemisphere emphasis, etc.

FORTUNA: An old Latin word for Part of Fortune, or PARS FORTUNAE. It is one of the Arabian Parts indicating where good fortune can manifest in the chart most naturally. One must know the exact minute of birth in order to calculate any of the Arabian Parts.

FRUITFUL SIGNS: The fruitful signs are the water signs: Cancer, Scorpio and Pisces.

GALACTIC CENTER: The gravitational center around which our Sun revolves. Astrology has suggested that the galactic center is at 0 degrees Capricorn. If this is the case, at the time of the winter solstice, the galactic center is only a few degrees South of the Sun. The Sun is placed about 30,000 light years from the center of our Milky Way galaxy. One complete orbit is estimated to be 200 million years. Its apparent motion is toward the star Vega in the constellation of Hercules. Some

For Your Notes

astronomers have ascertained the galactic center to be at 26 degrees Sagittarius, 10 minutes with a southern latitude of 5 degrees south, 32 minutes. Although astronomers disagree as to where the galactic center exists, one thing is certain: the galactic center of our galaxy is of a higher order hierarchical center of a system that is superior to the astrological order of our Sun.

GALAXY: From the Greek word meaning 'milk' as in the concept of the Milky Way. There are over one billion galaxies and each galaxy contains millions of stars, star clusters, nebula, planets, and inter-stellar dust, etc.

GRAND CROSS: This configuration is formed when two sets of oppositions are forming a square to each other. It is also known as a **GRAND SQUARE**. The grand cross tends to cause diffusion of a person's energies. See: T-Cross.

GRAND TRINE: When two planets are trined to each other and both of the planets are trined to a third, it is referred to as a grand trine. The ancient astrologers stated that it was very fortunate. Many modern astrologer feel that it causes a person to be lucky, but very lazy.

For Your Notes

GREATER BENEFIC: Designates the planet Jupiter, which brings greater benefits wherever it is found. The lesser benefic is the planet Venus.

GREATER MALEFIC: Designates the planet Saturn, which brings greater difficulties wherever it is found. The lesser malefic is the planet Mars.

GREENWICH: A suburb of London, England. It is the beginning point of the earth's longitudinal measuring system. Greenwich longitude is 0 degrees, 0 minutes, and 0 seconds, or 00:00:00.

GREENWICH MEAN TIME: The actual time at Greenwich, England related to a given time and place elsewhere on the earth.

HARMONICS: Harmonics are the basis of astrological aspects. It is established by dividing a number into the 360 degrees. For example, the first harmonic is one, divided into 360 degrees. This is 360 degrees, equaling the conjunction. The second harmonic is two, divided into 360 or 180, which is the opposition. The fourth harmonic is found by

For Your Notes

dividing 3 into 360. This gives 120, or the trine. The fourth harmonic would be 4 divided into 360, which is 90 degrees, the symbol of the square.

HELIOCENTRIC ASTROLOGY: The science of astrology based on observations from the Sun as the center of observation, thus using heliocentric longitudes and latitudes of the planets. Almost all astrology is based upon geocentric observations. Some astrologers believe that heliocentric astrology should be used when seeking evolutionary matters.

HEMISPHERES: A division of the celestial chart into halves. By a horizontal plane, it gives a southern and a northern hemisphere. On a vertical plane, it gives an eastern and a western hemisphere. The northern hemisphere consists of the first six houses. The eastern hemisphere consists of the 10th through the 3rd houses.

HERSCHEL: The planet Uranus. This planet was first discovered by William Herschel on March 13, 1781 and named after him. Later, the name 'Uranus' had been totally adopted by both astrologers and

For Your Notes

astronomers. The name 'Herschel' is occasionally found in old textbooks.

HORARY ASTROLOGY: The science in which a horoscope is constructed at the exact moment that a vital question is asked. By analyzing this horary chart, the answer to the question becomes apparent. The word 'horary' relates to the word 'hour.'

HORIZON: The circle around the earth separating the visible from the nonvisible hemisphere. In short, dividing the southern from the northern hemisphere. Which hemisphere is visible, depends upon whether you are living north or south of the equator.

HOUSE: The concept of the division of the zodiacal circle into 12 segments, which are conceived to be symbolic areas of earthly activity. There are four main house systems in use today, the most common being the Placidus house system. There are also the equal house system, as well as the Campanus house system, and the Regiomontanus house system.

For Your Notes

HOUSES, TABLE OF: See Table of Houses.

HUMANISTIC ASTROLOGY: A very modern school of astrological thought which emphasizes the individual's response to the symbols of the horoscope. Thus all interpretations are person centered, not event centered.

HYLEG: The meaning of 'hyleg' is 'the giver of life.' It is an ancient astrological concept that refers to principal places within the horoscope concerning longevity (not vitality). These principal places are usually centered around the Ascendant, the Midheaven and the Descendant. The hylegiacal places are the principal places for giving longevity. The Sun and the Moon in the hylegiacal places give longevity. The Sun and Moon also give a greater degree of vitality if they are placed in the 1st, 7th, 9th and 11th houses—the 1st being the greater giver of vitality, the 7th being the least effective.

IMUM COELI: The cusp of the 4th house or the lowest point in the heavens. Imum Coeli is Latin for the 'bottom of the heavens.' Thus it is oftentimes abbreviated I.C.

For Your Notes

INCONJUNCT: Also called a Quincunx. It is a not so minor, minor aspect. It measures 150 degrees. It causes stress, guilt and/or sickness.

INCREASING IN LIGHT: As the Moon moves from New Moon to Full Moon, it is known as increasing in light. When the Moon increases in light, it is the best time to begin or to manifest external activities.

INCREASING IN MOTION: A planet increases in motion or in acceleration as it approaches its perihelion. When a planet is approaching its apogee, it is slowest in motion. As a rule, the swifter the motion of the planet, the more the positive qualities will manifest. The slower the planet's motion, the more the negative qualities will tend to manifest.

INTERCEPTED: This refers to a sign totally contained within a house, thus the sign does not exist on any house cusp. It seems to indicate the events symbolized by the sign and its ruler are not easily or clearly seen. This interception occurs because of the irregular curvature of the earth.

For Your Notes

KARMA: The law of cause and effect. Although some Western astrologers tend to reject the concept of karma, most astrologers do accept the concept of karma and reincarnation, but not that of predestination. The horoscope, properly understood, indicates the accumulated actions and attitudes from the past, and thus is a symbolic map of a person's karma.

KEY-CYCLE: A system of progressions made popular by Sydney Bennett, under the synonym of 'WYNN.' It is based upon the fractional one quarter day excess, which is normally corrected every 4th year, as a leap-year day. By working with two successive Solar Returns and averaging them and then spreading this difference throughout the year, months and weeks, the 365 day calendar is reconciled with the actual 365-1/4 days as a predictive measurement.

LATITUDE: There are three kinds of latitude: astronomical, geocentric, geographic. Astronomical latitude is the angle between the direction of the plumb-line and the earth's equator. It is important to distinguish between geographical latitude measured north and south of the equator, and the celestial latitude measured north and south of the ecliptic. Geographical latitude is comparable to declination.

For Your Notes

LIGHT-YEAR: A unit of measurement equal to the distance that light travels in one year. Light travels at the rate of 186,000 miles per second. Therefore, a light year is approximately six trillion, or 6,000,000,000,000 miles.

LILITH: Sometimes referred to as the dark moon Lilith. It is really an asteroid, whose number is 1181. The symbol is the Greek letter 'theta.' There is an ephemeris existing for this important asteroid, which reveals the difficult karmic forces relating to mothers, women, etc.

LOCAL MEAN TIME: Based upon the moment when the mean Sun crosses the midheaven at the place of birth. LMT was universally used prior to the adoption of Standard Time, which occurred on November 18, 1883.

LONGITUDE: There are two types of longitude, terrestrial and geographical. Longitude is the distance of any point on the earth's surface, east or west of Greenwich. This distance is measured by astronomers in 'hours.' However, it is measured by geographers in 'degrees of arc.' Longitude begins at Greenwich (London), England, at 0 degrees, 0 minutes, 0 seconds. As the lines of longitude move east, they

For Your Notes

become east longitude. As the line of longitude move west, they become west longitude. They meet at the opposite side of the earth at 180 degrees.

LORD: The term referring to the ruler of a sign and or house. For example, Saturn is the Lord of Capricorn, as well as the house whose cusp has Capricorn on it. Or, Venus is the Lord of Taurus, as well as the house cusps which have Taurus and Libra on them.

LUMINARIES: Refers to the Lights in astrology, i.e., the Sun and the Moon. The Luminaries or the Lights are oftentimes referred to as planets to simplify communications.

LUNATION: Lunation refers to the phases of the Moon, the most important lunations being the Full and the New Moon.

MALEFIC: The term refers to certain planets considered to exert a more negative influence, particularly Saturn and Mars. However, in this sense, the planets Uranus, Neptune and Pluto are considered to be

For Your Notes

malefic. This term is also loosely applied to inharmonious aspects: the square, the opposition, and the negative conjunction.

MANSION [of the Moon]: Refers to the 28 mansions of the Moon, as opposed to the houses of the Sun. Each mansion represents the Moon's average (or approximate) distance traveled in one day. This is approximately 13 degrees. The actual mean distance traveled by the Moon is 12 degrees, 51 minutes and 25 seconds.

MASCULINE SIGNS: The odd numbered signs, or the fire and the air signs. Planets in masculine signs tend to manifest in an extroverted manner.

MEDICAL ASTROLOGY: That branch of astrology dealing with planetary causes of diseases. It also deals with healing and proper nutrition based upon the symbology of the horoscope.

MEDIUM COLEI: The Midheaven, or the cusp of the 10th house. It is abbreviated MC.

For Your Notes

MERIDIAN: The circles of longitude passing from the south point of the horizon through the zenith to the north point of the horizon. These coincide with geographical longitude. The prime meridian, or the prime vertical is the 10th house/4th house axis, referred to as the meridian of the horoscope.

MIDPOINT: That point in equal distance between two planets, or two planetary points. For example: the Ascendant and a planet. Midpoints are also referred to as half-sum.

MOVABLE SIGNS: Also referred to as cardinal signs, or leading signs. Planets in movable signs or cardinal signs manifest most powerfully.

MUNDANE ASTROLOGY: Mundane astrology is that branch of astrology which deals with the predicting of world trends and destinies of nations.

MUTABLE SIGNS: Also referred to as common signs. They are the signs of Gemini, Virgo, Sagittarius and Pisces.

For Your Notes

MUTUAL RECEPTION: Occurs when each of two planets are in the sign ruled by the other planet. For example, Venus in Aries and Mars in Taurus are said to be in mutual reception. This brings a very positive interaction between the two planets.

NADIR: The lowest point below the earth. It is the opposite point from the zenith. This should not be confused with the I.C.

NATAL ASTROLOGY: In the ancient days natal astrology was called 'genethliacal astrology.' It is that division of astrology that deals with the birth horoscope.

NATIVITY: An ancient term meaning the birth horoscope.

NODES, THE MOONS: Called by various names such as the Ascending Node and the Descending Node, the North Node and the South Node, the Dragon's Head and the Dragon's Tail, etc. Where the Moon's path crosses the ecliptic (the apparent path of the Sun), is referred to as the Moon's node. The Moon's motion changes radically and thus do the nodes. They are noted in the ephemerides. The North Node is given; the

For Your Notes

South Node is always the same degrees and minutes, but in the opposite sign of the North Node.

NODES, THE PLANETS: When a planet's path crosses the ecliptic (the apparent path of the Sun), from north to south or from south to north, that point of crossing is called the planet's node. The planetary nodes move very slightly each year.

OCCULTATION: A planet or a star hidden or eclipsed by another body (particularly by the Moon) is termed an occultation. The Moon often occults or eclipses planets. Occultation strengthens the force of that conjunction, be it negative or positive. The Sun rarely eclipses a planet.

OPPOSITION: A major astrological aspect based upon the 2nd harmonic. Its measurement equals 180 degrees and is an obstructive force, indicating tension developing between the opposing planets.

ORB: The distance between two planets (or points) by which an aspect is determined. The term 'orb' is employed to determine the arc between two planets (or points), at which *platic*, or wide aspect, is considered

For Your Notes

strong enough to be operative. At *partile*, or exact aspect, the force is most dynamic. Most astrologers disagree as to the various orbs. Technically, all planets are related to all other planets—independent of their degrees of separation. However, the five major aspects reveal very clear relationships and actions when the planets are in orb. All astrologers agree that the larger planets have larger orbs and that the smaller planets, smaller orbs, as well as the fact that the closer to partile an aspect is, the stronger the force of that aspect.

Ptolemy, an ancient astrologer, who wrote 'The Tetrabiblos' ('The Four Books'), gives the following orbs: Sun, 17; Moon 12; Jupiter 12; Saturn 9; Venus 8; Mercury and Mars 7. Some astrologers give Uranus, Neptune and Pluto an orb of 5 degrees. You take the two planets, add up the orbs and then divide by two. The figure given is the plastic orb of these two planets. For example, an opposition of the Sun and Uranus would be 17 plus 5, which equals 22. Divided by two gives a plastic orb of 11 degrees. With all due respect to Ptolemy, these orbs are too wide for the beginner to use. Much smaller orbs of 7 to 3 degrees should be used to begin with. Once you have gained a better insight into astrology, you can open up the orbs according to the nature of the chart: a planet angular, a planet conjuncting a cusp, planets in mutual reception, etc.

For Your Notes

ORBIT: The path described by a planetary body in its revolution around the center of attraction.

ORIENTAL or EASTERN: This is a term applied to the rising of a planet over the Ascendant in a *clockwise* direction (because the movement of the signs is faster than the counterclockwise direction of the planets). Thus the oriental planet is the planet rising immediately before the Sun rises.

PART OF FORTUNA: The Part of Fortune.

PARTILE: An exact aspect; an aspect which has no orb whatsoever.

PERIGEE: That point in a planet's orbit that is nearest to the earth. A planet at perigee is at the closest point that it will get to the earth.

PERIHELION: That point in a planet's orbit that is closest to the Sun.

For Your Notes

PLACIDEAN: The house system devised by the Spanish monk Placidus de Titus, in the 17th century.

PLATIC: The widest orb between two planets (or points in a chart) in which the aspect is deemed to be operative, although very weakly so.

POSITIVE SIGNS: The odd numbered signs, or the masculine signs, which compose the Fire and Air signs.

PRECESSION OF THE EQUINOX: The shape of the earth is an ellipsoid, not a sphere as many think. It is flattened at the poles and bulging at the equator, caused by the gravitational pull of the Sun and the Moon. This pull causes the earth's poles to gyrate slightly like a spinning top (just before it falls over). A reference point to this wobbling, zodiacally, is that it appears to retrograde, or to precess. Thus the name 'precession of the equinox.' This precession moves approximately 50.27 seconds (not minutes) per year. It therefore makes a zodiacal full circle in approximately 25,800 years. The precession in each zodiacal sign is called an age: the Piscean Age, the Age of Aquarius, etc.

For Your Notes

PRIMARY DIRECTION: Any method based upon the diurnal rotation of the earth upon its axis. Primary directions are spherical, trigonometric projections of planets into aspect after birth, based upon the actual rotation of the earth once every 24 hours.

PRIME VERTICAL: The great circle connecting the zenith point directly over head and the nadir point directly opposite it.

PROGRESSED HOROSCOPE: A chart erected for a date that is as many days after the birthday, as the person's age in years.

QUADRANTS: The four quarters of the horoscope represented by the four quarters of the chart. These are measured from the cusps of the four angular houses.

QUADRUPPLICITY: The three groups of signs having the same quality. These are the cardinal signs, the fixed signs, and the mutable signs.

For Your Notes

QUINCUNX: An old fashioned term for the inconjunct, or the aspect of 150 degrees.

RADICAL: Also called RADIX. It refers to, or pertains to, the natal horoscope.

RECTIFICATION: The process of correcting or of reverifying the birth moment (or the exact degree and minute of the Ascendant). This is done by reference to known events. Occasionally, rectification is accomplished by marked personality characteristics of the person whose chart is being rectified. However, generally ten major life events are needed for a proper rectification.

REGIOMONTANUS: Regiomontanus is a pseudonym for Johannes Muller, who lived in the 15th century. He is the creator of one of the four major house systems.

RETROGRADE: Retrograde means the backward motion of a planet in the zodiac when it is decreasing in longitude, as viewed from the earth. This apparent backward motion of the planet is caused by its slowing

For Your Notes

down during its turn in its elliptical orbit, as the earth accelerates, or appears to accelerate in its actual rotation. The Sun and the Moon never go retrograde. All the planets go retrograde at some time. A planet goes retrograde for a short time, reverses its direction, and goes direct again. All of this apparent motion occurs against a stationary backdrop of the zodiacal stars. Because of retrograding, a transiting planet can 'hit' or activate a natal planet three times. The one exception is the planet Pluto, which can 'hit' or activate a natal planet five times!

REVOLUTION: One complete rotation of a planet.

RIGHT ASCENSION: The distance measured along the celestial equator Eastward from 0 degrees Aries.

SECONDARY PROGRESSIONS: A predictive technique based upon the symbolism of one day after birth equaling one year of the native's life.

SEXTILE: A 60 degree aspect. One of the five major aspects based upon the 6th harmonic. It is an 'opportunity' aspect and has the nature of Venus.

For Your Notes

SIDEREAL TIME: ‘Sidereal’ means star. Thus, sidereal time is star time, which is the basis of astrological calculations. It is a method of reckoning time based upon the period elapsing between two successive passages of a given star.

SIGNIFICATOR: The planet taken as signifying a person or an event ruled by a house.

SIGNS: The signs of the zodiac are 12 in number based upon ancient observation of star constellations on or near the Sun’s ecliptic. Signs are used as a reference point for the planets in their motion. The word ‘zodiac’ means a circle of animals. Because of the precession of the equinox, today, the zodiac and the constellations have separated by approximately 24-1/4 degrees.

SOLSTICES: The points on the ecliptic in which the Sun is at its greatest distance north or south. Thus, at these points the Sun appears to stand still. The summer solstice occurs when the Sun enters 0 degrees Cancer, approximately June 21st. The winter solstice occurs when the Sun enters 0 degrees Capricorn, approximately December 21st.

For Your Notes

SPECULUM: A table linked to the horoscope indicating various astrological factors: the aspect, the elements, the declinations, etc. In modern language it is referred to as the 'aspect grid' or the 'grid aspect,' and contains the tabulated aspects between planets.

SQUARE: An aspect of 90 degrees. It is the 4th harmonic, and has the nature of Mars, showing a destructive force.

STATIONARY: A planet is said to be stationary when it appears to have no apparent motion. This occurs when a planet changes direction, from direct to retrograde, or from retrograde to direct. Thus, a planet can be stationary direct when the planet is stationary, but is going to move direct. Or, it can be stationary retrograde, which means that it is stationary, but is going to move retrograde. The stationary position of a planet markedly increases the force of that planet, for better or worse. Stationary direct gives more positive energy than stationary retrograde.

STELLIUM: In the far distant past, this was referred to as a **SATELLITIUM**. It is a group of five or more planets in one sign or house. A stellium symbolizes an area of great importance in a person's

For Your Notes

life, which at some point in that life will, most likely, bring great recognition.

SUCCEDENT HOUSES: The 2nd, 5th, 8th and 11th houses.

SUPERIOR CONJUNCTIONS: Conjunctions existing between the planets outside of Saturn's orbit, i.e., Uranus, Neptune and Pluto.

SUPERIOR PLANETS: Those planets which lie outside, or beyond the earth's orbit. These are the planets Mars and all the planets beyond Mars. INFERIOR planets are those planets which lie inside the earth's orbit: Venus and Mercury (and some say the planet Vulcan).

TABLE OF HOUSES: A book containing the degrees of the signs which occupy the cusps of the 10th through the 3rd houses at different latitudes for every degree of right ascension. It is by means of the Table of Houses for the different latitudes that the astrologer is able to determine the Ascendant and the other house cusps.

For Your Notes

T-CROSS: The T-Cross is formed when two planets are in opposition with each other, and both are squaring a third planet. Also called the T-square, it manifests a release of dynamic energies toward that planet that is doubly squared. If a fourth planet is in opposition to this third planet, it is called a Grand Cross. See: Grand Cross.

TRANSIT: The ephemeral passage of a planet over another planet or over a place in the horoscope. Transits are taken out of the ephemeris for the current month, day, and year in which one is interested.

TRANSLATION OF LIGHT: Translation of light occurs when a transiting planet, while separating from an aspect of one planet, is found to form another aspect to another planet. Thus, some of the force of the first aspect is transferred or translated to the second aspect. The process of the transference is by what is called the 'translation of light.'

TRIGON: A term applied to the three signs of the same triplicity, be that Air, Earth, Fire or Water.

For Your Notes

TRINE: The 3rd harmonic or an aspect of 120 degrees. It has the nature of Jupiter and is referred to as the good luck aspect.

URANIAN ASTROLOGY: A system of Astrology based upon the Hamburg School of Astrology formed by Alfred Witte. Its key factor is the utilization of midpoints, as well as eight further 'symbolic indicators', referred to as 'unknown planets.' These unknown planets were postulated, not only by Witte, but also by Friederich Sieggrun. The third major difference is that they exclude all the aspects except the hard angles, i.e., the conjunction, semi-square, square, sesquiquadrate (135 degrees), and opposition.

VERNAL EQUINOX: The Sun's entrance into zero degrees Aries.

VERTEX: The vertex is called the third angle of the horoscope. The vertex is calculated by subtracting the birth latitude from 90 degrees to find what is called the 'co-latitude.' You then take the sign and the degree upon the fourth house cusp and conceive it as being the midheaven (as a reference point in the table of houses). Then you find this reference point under the midheaven and take the Ascendant listed

For Your Notes

for it. This listed Ascendant is known as the vertex, and seems to indicate a focus regarding fateful events in one's life.

VERTICAL: The same as prime vertical.

VIA COMBUSTA: This means the 'path of combustion', the path of fire. The ancient astrologers refer to this as a cluster of fixed stars in the early degrees of Scorpio. Therefore, if the birth Moon was found in the early degrees of Scorpio (in Via Combusta), the Moon was considered to be heavily afflicted (as if it were totally eclipsed).

VOID OF COURSE: In ancient times, void of course referred to any natal planet which formed no major aspects before leaving the sign it was in. In modern times, this refers to the period of time from the last major aspect of the Moon, until it leaves that sign. In a natal chart when the Moon is void of course, it tends to nullify much of the positivity promised in the natal chart. The personality is also somewhat eccentric. In Horary Astrology, events begun under void of course will have no major continuing activity. Therefore, many people will go to court under void of course, or file their income taxes then, hoping that further action will be voided.

For Your Notes

VULCAN: A symbolic planet much used among ancient astrologers. Its orbit lies inside that of Mercury. In modern times, no concrete confirmation has occurred from astronomers.

WAR TIME: See Daylight Savings Time.

ZENITH: The highest point in the horoscope, i.e., the 10th house cusp.

ZODIAC: See Signs.



For Your Notes

ANSWERS:

*How to Become a Practicing Astrologer
Self-evaluation Test #1*

1. ♀
2. ♀ or ♃
3. ♂
4. ♀
5. ☾
6. ☿
7. ♃
8. ♃
9. ♃
10. ☉
11. ♃ *

For Your Notes

*(Answer to question #11: This is the symbol used by a few American astrologers and almost all of the European astrologers, the option is yours to use.)

If you did not do very well on Test #1 or are unclear of the symbols of the planets, you may want to go back and reread pages 6-7 and 9-14 of *The Wisdom and Way of Astrology* to understand the formation of the planetary symbols as well as the symbols themselves.

*All page numbers refer to *The Wisdom and Way of Astrology* by Goswami Kriyananda, unless otherwise indicated.



For Your Notes

ANSWERS:

How to Become a Practicing Astrologer
Self-evaluation Test #2

1. Energy, Heat, Activation
2. Nebulousness, Impressionability, Inspiration
3. Expansion, Optimism, Preservation
4. Power, Vitality, Self-Expression
5. Communication, Mentality, Transportation
6. Renewal, Regeneration, Elimination
7. Fluctuation, Emotionality, Response
8. Harmony, Love, Beauty
9. Unexpected, sudden, disruptive or revolutionary change
10. Limitation, Constriction, Foundation

If you did not do as well as you would have liked to on Test #2, please reread pages 9-14 of *The Wisdom and Way of Astrology*.



For Your Notes

This is a blank page.

For Your Notes

ANSWERS:

How to Become a Practicing Astrologer
Self-evaluation Test #3

1. + Good Judgment, Diplomacy, Articulate
 - Careless, Indecisive, Nervous
2. + Magnetic, Inventive, Ingenious
 - Rebellious, Extreme, Irresponsible
3. + Receptive, Domestic, Adaptable
 - Shy, Non-caring, Moody
4. + Sympathetic, Intuitional, Poetic
 - Vague, Deceptive, Obsessed
5. + Affectionate, Graceful, Refined
 - Untidy, Gaudy, Excessive
6. + Energetic, Expressive, Determined
 - Harsh, Reckless, Destructive
7. + Responsible, Hard-Working, Self-Disciplined
 - Melancholic, Pessimistic, Narrow-Minded
8. + Rejuvenating, Transforming, Regenerating
 - Fanatical, Reckless, Notoriety

For Your Notes

9. + Justice-Seeking, Generous, Compassionate
- Extravagant, Indulgent, Yearning for Pleasure
10. + Loyal, Dignified, Generous
- Arrogant, Dictatorial, Lack of Vitality

On each test requiring key word answers, it does not matter whether you respond with the exact words that are given in the written materials, but that the word(s) you have chosen have the same *meaning* or are in agreement with them.

If you did not do as well as you would have liked to do on Test #3, or if you want to clarify your position, please reread *The Wisdom and Way of Astrology*, pages 17 through 57. You can find these in the symbolic psychological meaning of each planet on pages: 17, 21-22, 25, 28-29, 31, 34-35, 38, 43, 52, and 56.

Having reread the harmonious and inharmonious nature of each planet, you will find the summary of the answers on page 60.



For Your Notes

ANSWERS:

How to Become a Practicing Astrologer
Self-evaluation Test #4

1. 

2. 

3. 

4. 

5. 

6. 

7. 

8. 

9. 

For Your Notes

10. ♀

11. ♎

12. ♂

If you did not do as well in this test as you would have liked to, repractice with your flash cards, and also study page 63 of *The Wisdom and Way of Astrology*.



For Your Notes

ANSWERS:

How to Become a Practicing Astrologer
Self-evaluation Test #5

1. Creatively, Joyfully, Devotedly
2. Communicatively, Mentally, Versatilely
3. Penetratingly, Passionately, Secretively
4. Protectively, Cautiously, Emotionally
5. Detachedly, Scientifically, Coolly
6. Assertively, Courageously, Energetically
7. Possessively, Enduringly, Industriously
8. Nebulously, Inspirationally, Confusedly
9. Widely, Deeply, Philosophically
10. Harmoniously, Unitedly, Sociably
11. Analytically, Detailedly, Critically
12. Prudently, Aspiringly, Efficiently

If you did not do as well as you would have liked to do on Test #5, go to *The Wisdom and Way of Astrology* and reread or restudy the key attributes of each zodiacal sign found in the boxed sections for each sign on pages 68, 72, 76, 80, 84, 90, 94, 98, 101, 105, and 108.

For Your Notes

Also, by studying the positive and negative psychological attributes of the zodiacal signs, you will have a clearer understanding of their meaning. The main concept to understand is that the key attributes should be adverbs (ending in 'ly'). You do not have to have the same exact words as in the written materials, but the words should have the same meaning.



For Your Notes

ANSWERS:

How to Become a Practicing Astrologer
Self-evaluation Test #6

1. Personality, Worldly outlook, Self-interests
2. Long journeys, Higher education, Foreign countries
3. Father, One's profession, Honor/Fame
4. Mother, Home environment, End of life
5. Sickness, Servants/Service, Work
6. Mind, Brothers and sisters, Short journeys
7. Self-help/Self-undoing, Confinements, Secret sorrows/Secret enemies
8. Marriage/Partnerships, Open enemies, General public
9. Friends/Associates, Hopes and dreams, Organizations
10. Death, Other people's money, Astral or occult experiences
11. Financial affairs, Memory tract, Possibilities of losses or gains of things
12. Love affairs, Children, Creativity

For Your Notes















If you are not satisfied with your answers, please study the houses (the key life areas) in *The Wisdom and Way of Astrology*, pages 116-124.



For Your Notes

ANSWERS:

How to Become a Practicing Astrologer
Self-evaluation Test #7

1. 2 planets can form an aspect even though their distance from one another is not exact.
2. 
3. 
4.    
5. 
6. 
7. 
8.      

If you are not satisfied with your answers, go to *The Wisdom and Way of Astrology* and reread or study carefully page 128 and the paragraph on orbs of influence on pages 127 and 137.

For Your Notes

As you can see, orbs of influence are not specific. The secret is to know that the further from partile, the weaker the aspect; the closer to partile, the stronger the aspect.



For Your Notes

ANSWERS:

How to Become a Practicing Astrologer
Self-evaluation Test #8

1. Power
Forceful, dynamic, crystallizing and energizing.
2. Luck
Favorable, expansive, optimistic.
3. Disruptive
Negative, discordant, disturbing, and conflicting.
4. Opportunity
Harmony, warmth, love and ease.
5. Obstructive
Duality, negative, changeable

If you are not satisfied with your answers, please reread or study carefully pages 125-140 in *The Wisdom and Way of Astrology*.



For Your Notes

This is a blank page.

For Your Notes

ANSWERS:

How to Become a Practicing Astrologer
Self-evaluation Test #9

1. Libra
2. It is both an art and a science.
3. Gemini, Libra, Aquarius
4. He is a doer, he loves activity and change.
5. 360 degrees
6. Aries, Cancer, Libra, Capricorn
7. Sun and Moon
8. Astrology is the understanding of certain cryptic relationships between celestial phenomena and earth life forms—human, animal, plant, and mineral.
9. Creative, enthusiastic
10. An ephemeris is a book listing the daily planetary positions.
11. Adaptability and versatility
12. Clockwise
13. 12
14. Intellectual, social, talkative
15. 30 degrees
16. Conservative, resistant to change

For Your Notes

17. Aries, Leo, Sagittarius
18. Counterclockwise
19. Gemini, Virgo, Sagittarius, Pisces
20. Cancer, Scorpio, Pisces
21. Emotional, creative, perceptive
22. Material, dependable, down to earth
23. Taurus, Leo, Scorpio, and Aquarius
24. Taurus, Virgo, Capricorn
25. The Table of Houses is a book that lists the sign and cusp degrees at different latitudes.



For Your Notes

ANSWERS:

How to Become a Practicing Astrologer
Self-evaluation Test #10

1. Inspirational (not aspirational)
2. The Ascendant
3. 12
4. 15 to 45 degrees, depending upon the latitude of one's birth
5. The 1st house and the 7th house
6. Practical
7. Midheaven
8. Internalize
9. 1st, 4th, 7th, and 10th
10. The angles
11. Emotional
12. 10th and 4th house cusps
13. Aspirational, intellectual
14. The cosmic urges
15. The modifying mode of the planetary urges

For Your Notes

16. Where the modified urges will manifest
17. The intensity of the karmic energy and whether it is harmonious or inharmonious



For Your Notes

ANSWERS:

How to Become a Practicing Astrologer
Self-evaluation Test #11

MALE:

Born May 18, 1920

1. With friends, with organizations and with leaders of organizations. The leaders of organizations would be symbolized by Aries, which is the sign on the 11th house cusp.
2. The 12th house
3. The 11th house
4. The 11th house
5. Probably not, because of the Sun squaring Saturn and Saturn is the ruler of the 7th house
6. In the 9th house of religion, philosophy and travel
7. Libra or an air sign on the 5th house indicates enjoyment in intellectual activities.
8. The Sun rules those things close to the person's heart and also the vitality.
9. Mercury in Taurus causes a person to want to sustain things that have been established, as well as to consolidate financial conditions.

For Your Notes

10. The 5th house of pleasure, creativity, and the way he relaxes; the intercepted 11th house of friends, dreams, hopes
11. In his home environment, in the 4th house
12. His heart is linked to friends, organizations, and his dreams.
13. In the 2nd house
14. Poor because of the Sun squared Saturn
15. Pluto does not rule a house, since it is intercepted in the 5th house. (Venus rules the 5th house.) One could say that the sub-ruler of the 5th house is Pluto.
16. The Ascendant, or the 1st house
17. Yes, Neptune is in the 2nd house squaring Venus. Since Venus is a symbol of money (and in general, naturally associated with the 2nd house), the fact that it is squaring Neptune indicates there could be problems of confusion or deception in the area of money matters.
18. Zealousness or motivation to break free of his confinement, and possibly of his early childhood training. (This would be indicated by Pluto located in the sign of Cancer).
19. The 2nd house of wealth and the 3rd house of communications

For Your Notes

20. The 4th house and the 12th house
21. In the 3rd house—his communications, and in all 3rd house matters



For Your Notes

This is a blank page.

For Your Notes

ANSWERS:

How to Become a Practicing Astrologer
Self-evaluation Test #12

MALE

Born October 26, 1916

1. Libra
2. The 10th house cusp
3. No, they do not because Mars is trine Saturn.
4. Pluto. Not because of the trine or sextile, but because it is within 2 degrees of the cusp of the 10th house, indicating marked fame in the person's life.
5. 5th house cusp: Aquarius
9th house cusp: Gemini
2nd house cusp: Scorpio
6. Aries or a fire sign on the cusp of the house of marriage tends to indicate marriage. Mars is trined Saturn and trined Neptune, which would tend to indicate obligations from the past and strong tendencies to form a relationship with a woman that is long lasting and spiritually significant.
7. The 1st house - Mercury in Libra. Mercury in Libra in the 1st house causes the person to be curious about himself

For Your Notes

- (1st house) and about the general public or people in general (Libra).
8. Cancer
 9. Yes, because Pluto deals with masses of people and is an indicator of unusual fame.
 10. In the 1st house
 11. In the 5th house
 12. Mercury
 13. Neptune
 14. Jupiter—the house of partnerships, marriage partnerships and the general public
 15. Libra
 16. Mercury
 17. Fame—Pluto the planet of motivation is conjunct the 10th house of fame.
 18. Yes—Mercury trined Uranus
 19. Feminine
 20. Moon opposed Jupiter and Moon squared Saturn
 21. Angular

For Your Notes

22. Although Neptune is trined Mars, indicating help through chemotherapy and/or surgery, Neptune forms three difficult aspects: Sun squared Neptune, Jupiter squared Neptune, and Saturn conjunct Neptune, indicating a high potentiality that this person will have major sicknesses lasting for extended periods of time.
23. The Ascendant, Mercury, Moon, Mars, Uranus, Descendant, Saturn, and Neptune
24. Uranus—5th house of happiness or pleasure. Uranus would tend to indicate that creativity and feeling free or unburdened would cause this person to be happy. Strong intellectual stimulus (Mercury/Uranus) would also give this person pleasure.
25. Saturn in the 10th house indicates he needs perfect timing in his career and also in dealing with powerful, influential people or with authoritarian figures.
26. It is in greater disharmony because the majority of his planets and house angles are masculine, so there's a conflict between all that excessive masculinity and the feminine Sun-sign. (His feminine Sun-sign is also opposing Jupiter.)
27. Aries, assertive, active, extroverted. Mars the ruler of the 7th house trined Saturn indicates she would have superb timing, be consistent and persistent. Mars trined Neptune

For Your Notes

indicates she would tend to be highly intuitional and very artistic, enjoying art and artistic creativities. Jupiter in the house of marriage opposed the husband's Moon indicates conflicts or differences of opinions in philosophy, in making changes, and in dealing with women and/or the general public.

